



SERVICE MANUAL

for the

KODAK EKTAPRO Slide Projector

Model 4020, 5020, 7020, 9020, (9020/CINE)

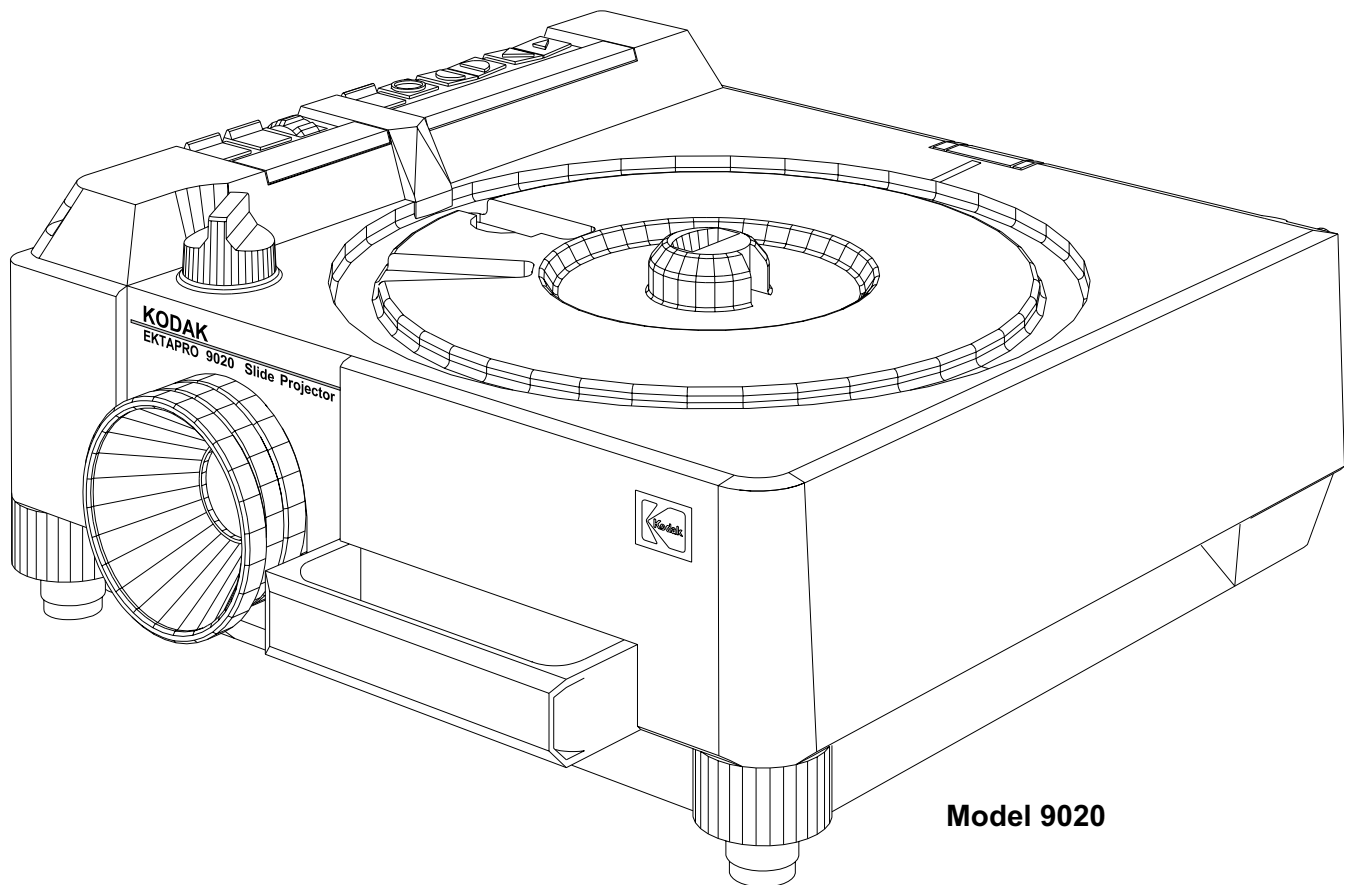

Model 9020

PLEASE NOTE

The information contained herein is based on the experience and knowledge relating to the subject matter gained by Kodak prior to publication. No patent license is granted by this information. Kodak reserves the right to change this information without notice, and makes no warranty, express or implied, with respect to this information. Kodak shall not be liable for any loss or damage, including consequential or special damages, resulting from the use of this information, even if loss or damage is caused by Kodak's negligence or other fault.

TABLE OF CONTENTS

ELECTROSTATIC DISCHARGE	1-1
Overview	1-1
Awareness	1-1
Action	1-1
Every Day	1-2
During Maintenance and Repair	1-2
1. GENERAL INFORMATION	1-3
Service Tools	1-3
For Models 4020/5020/7020/9020 and 9020/CINE	1-3
Safety Precaution.....	1-4
Safety Check	1-5
2. INTRODUCTION	2-1
Projector Models	2-2
EKTAPRO Model 4020.....	2-2
Features and Functions:	2-2
EKTAPRO Model 4020.....	2-3
EKTAPRO Model 5020.....	2-4
Features and Functions:	2-4
EKTAPRO Model 7020.....	2-5
Features and Functions:	2-5
EKTAPRO Model 9020.....	2-6
Features and Functions:	2-6
Overview	2-7
Accessories.....	2-8
DUAL LAMP MODULE	2-8
CABLE REMOTE	2-8

CONDENSER KIT 4X4 (with CLIP).....	2-9
IR REMOTE System RA/LP (Laser Pointer)	2-10
12/7-PIN MODULE	2-10
LENS SUPPORT.....	2-10
12/7-PIN ADAPTER CABLE.....	2-11
TWIN SOCKET ADAPTER.....	2-11
SLIDE SYNCHRONIZER	2-12
LAMPS	2-12
Specification.....	2-13
CONNECTORS	2-13
Remote SOCKET on Projector:.....	2-13
P-Bus / RS 232 "IN"	2-14
P-Bus / RS 232 "OUT"	2-14
ACCESSORY SLOT.....	2-15
OEM ACCESSORIES	2-16
COPYWRITE	2-16
SLIDE SYNCHRONIZER ADAPTER by KODAK AUSTRALIA.....	2-17
ADAPTER by MÜWO	2-18
ADAPTERS by MAYER & ZELLER.....	2-19
ADDRESSES	2-20
CONTROL SYSTEMS.....	2-20
SOFTWARE for direct PC CONTROL.....	2-21
RACKS	2-21
EXTERNAL TIMER	2-21
3. THEORY GUIDE	3-1
Block Diagram.....	3-1
Microcontroller Unit.....	3-3
Description of Functions	3-4

Power Supply	3-4
The TRANSFORMER supplies the following voltages:	3-4
The POWER REGULATION PCB contains:.....	3-4
The output voltages and signal are:.....	3-4
Switch On / Initialize Procedure.....	3-6
Slide Change Sequence.....	3-7
Tray Motion.....	3-8
Tray Motion Sequence:	3-9
LAMP Control	3-11
a) Dual LAMP Operation	3-11
b) Low/High LAMP Setting	3-12
c) LAMP Protection.....	3-12
d) LAMP Voltage Control.....	3-12
e) Lamp Dimming	3-13
Focus.....	3-15
Auto focus.....	3-16
P-BUS	3-17
Command Structure	3-18
Accessory slot	3-19
Remote Control	3-20
4. DISASSEMBLY/ASSEMBLY	4-1
UPPER HOUSING.....	4-1
BUTTONS and COVER PLATES.....	4-2
Assembly	4-3
CENTER HOUSING	4-4
FAN, KEYBOARD PCB and TRAY MOTION PCB.....	4-8
BACK PANEL PCB.....	4-10
TRANSFORMER, POWER SUPPLY PCB and BACK PLATE ASSEMBLY	4-11

MECHANISM FRAME and LENS MOUNT	4-12
LENS MOUNT	4-13
Model 4020/7020	4-15
RETAINER AF ASSEMBLY	4-16
Model 5020/9020 and 9020/CINE	4-16
MECHANISM FRAME	4-18
AUTO FOCUS PCB and FOCUS MOTOR	4-21
Master Board PCB	4-22
Master Board PCB Connectors	4-23
MICROCONTROLLER	4-24
LOWER HOUSING	4-25
DUAL LAMP MODULE	4-26
DUAL LAMP MODULE	4-29
Lubrication	4-30
5. DIAGNOSTICS	5-1
Diagnostic Overview EKTAPRO 4020/5020/7020/9020 and 9020/CINE	5-1
Preparation	5-3
Conditions:	5-3
No Function	5-4
Switch on Procedure Problems	5-9
Lamp Problems EP 4020/5020/7020/9020 and 9020/CINE	5-12
Mirror Position	5-17
Brightness Test	5-17
Switch On Procedure	5-18
Switch On Procedure complete - No Keyboard Function	5-19
No function with REMOTE CONTROL	5-20
IR Remote Control	5-20
Cable Remote	5-23

No Slide Transport forward/reverse and other projection problems	5-24
Shutter Problems	5-35
Fan Problems.....	5-27
Slide Obstruction in Slide Tray.....	5-29
Conditions for a correct transport cycle	5-29
Wrong Transport Step by 80/140 SLIDE TRAY	5-30
No Focus Actuation.....	5-32
No Standby Function	5-33
Communication Trouble 4010/5010/9010.....	5-35
AUTO FOCUS 5020/9020 and 9020/CINE: No AUTO FOCUS Function.....	5-39
Accessory Slot 7020/9020	5-40
Malfunction of the 12/7 PIN Module.....	5-40
6. Projector Checking	6-1
Slide Transport Problems	6-1
Slide jam (all models)	6-2
CODER DISK	6-2
7. MAINTENANCE	7-1
Maintenance Intervals.....	7-1
Maintenance Procedure.....	7-1
Cleaning.....	7-1
Ultrasonic cleaning	7-2
Lubrication	7-3

blank page

ELECTROSTATIC DISCHARGE

CAUTION

This equipment includes parts and assemblies sensitive to damage from electrostatic discharge. Use caution to prevent damage during all service procedures.

Overview

Electrostatic discharge (ESD) is a primary source of

- product downtime
- lost productivity
- costly repair.

While we cannot feel a static charge of less than 3,500 volts, as few as 30 volts can damage or destroy essential components in the electronic equipment. As technology advances, these components will be even more vulnerable to ESD destruction.

Therefore, to maintain and increase productivity and profitability, you must observe ESD guidelines.

Effective ESD control requires the following things.

Awareness

Everyone in your organization should be aware of ESD because partial ESD control is no ESD control at all. Everyone needs to remember that:

- ESD is a primary source of equipment failures and intermittent malfunctions.
- ESD affects productivity and profitability.
- ESD can be controlled.

Action

Everyone from senior management to the evening security crew, must observe ESD guidelines.

- If you repair and maintain electronic equipment, always wear grounding straps and work at ESD protected sites.
- If you work around electronic equipment, keep static generators like plastic trash bags away from sensitive components.
- Observe ESD guidelines everyday. (See the following sections for special tips).
- Remember, effective ESD control is everyone's responsibility:

Every Day

1. Keep trash away from static-sensitive equipment. Plastic materials, such as trash can liners and plastic foam cups, generate the static electricity that damages or destroys electronic components.
2. Look at the label. Static-sensitive components are marked with bright graphic labels. Follow the label directions.
3. Spray the carpet. ESD that is generated when you walk over carpet is a major cause of component destruction. In some cases, especially in low-humidity environments, you may need to periodically spray carpets with an anti-static spray that is available at local stores.

During Maintenance and Repair

1. Wear a grounding strap when you work with static-sensitive components. Always make certain that the clip is attached to a properly grounded, unpainted surface.
2. Use a portable grounding mat if you cannot repair components at an ESD-protected workstation. (Kodak's Customer Equipment Services Division can help you in set up ESD-protected workstations.)
3. Use protective packaging when you transport components from one area to another. Transparent antistatic bags, available from a variety of manufacturers, shield the components from further damage.

1. GENERAL INFORMATION

Service Tools

Use the following tools to repair a KODAK EKTAPRO Slide Projector:

TORX Screw Driversize 206

TORX Screw Driversize 210

TORX Screw Driversize 215 or TORX bits TL-3255

TORX Screw Driver size 220

Logic Probe TTL/CMOS

Oscilloscope - only for checks on the AUTO FOCUS PCB.

Digital Multimeter	Voltage	5 to 240 V AC	
		0 to 50 V DC	
	Current	1 to 100 mA DC	Accuracy: 1%
		0,1 to 2 A DC	
		0,1 to 5 A AC	
		The multimeter should have RMS capability	
	Accuracy	1%	

Fixture Tool 622 0454

For Models 4020/5020/7020/9020/9020/CINE

PLCC Extractor Tool TL-4430

Service Computer 100% IBM compatible

- Hard disk
- CGA/EGA/VGA Monitor/Display
- 1 RS 232 Serial Interface
- 1 Centronics Printer Interface
- 1 720kB Floppy Disk Drive
- 1 9pin Serial Interface CORD

Diagnostic Software: TL-4575

Ejector Microcontroller G 990 3250

Safety Precaution

- 1.** Do not operate or repair the projector without proper accessories. Add all COVERS before use to prevent mechanical hazards and electrical shock.
- 2.** Before operating the projector, check the VOLTAGE SELECTOR. Make sure that the correct line voltage is selected.
- 3.** Do not use a damaged POWER CORD. The damaged CORD can cause malfunctions and current leakage or electrical shock.
- 4.** If there is any abnormal noise, smell or smoke during operation, deenergize the projector immediately and contact authorized personal for support.
- 5.** Do not operate the projector in unsafe locations such as outdoors or in wet places. Do not allow liquids, gaseous or solid-state materials to enter the projector.
- 6.** When doing electrical measurements, use an isolation transformer or a leakage current detector in the power line to avoid an electrical shock.
- 7.** Use only original parts from the Parts List to repair the projector.
- 8.** Make sure that the requirements of UL 122 - Splices and Connection - paragraph 13.10 and EN 60 950, section 4.39 are observed. When replacing AC primary components, such as wires, sockets or capacitors , wrap the ends of the wire completely around the terminal before soldering.

Safety Check

NOTE

Check the area around the repaired location.

Make sure that parts and wires have been returned to the correct positions.

Completely assemble the projector before doing an electrical safety test.

The safety tests:

Ground Continuity Test
Insulation Resistance Test
Equivalent Leakage Current Test

Use a safety tester that measures all 3 tests at one time.

Such a test device would be a Mini Tester 0701 N (Manufacturer:Gossen, Germany) or an equivalent device.

Details for safety standards can be found in the regulations:

IEC 380, 435, 950,
UL 478, 1012.

Prerequisites for measurements:

- The projector is energized
- FUSE with VOLTAGE SELECTOR insert
- COVERS in place
- LAMP MODULE installed

Test values for Mini Tester 0701N

- Ground Continuity Test< 300 mOHM
- Insulation Resistance Test< = 0,5 OHM
- Equivalent Leakage Current< = 7 mA

Interfaces

Models 7020 and 9020 have an accessory slot. The 7/12pin module from Kodak is safety tested, and has approval from VDE and other institutions. If an OEM module is installed, inform the customer:

- the OEM is responsible for the safety and function of the module.
- the module is not part of the repair order.
- the specifications and safety warnings for the accessory in the slot are found in the "Operator's Manual".

blank page

2. INTRODUCTION

The Kodak EKTAPRO Slide Projector series is a new family of Projectors that uses the latest mechanical and electronic technology.

The Projector is modular designed, and equipped with a modern 1-chip MICROCONTROLLER, STEPPER MOTORS, optical sensors, and digital and analog circuits. All functions and displays are controlled by the MICROCONTROLLER software.

Four models with different features and functions are available worldwide top 2 models can be attached to the old CAROUSEL and EKTAGRAPHIC family processors with optional ADAPTERS in the accessory slot. This new feature allows the future use of other equipment manufacturers Projector systems and accessories.

The Models 4020, 5020, 7020 and 9020 are equipped with an RS 232 interface (P-Bus). This bus allows communication with a computer and multi Projector shows in a new way. The P-Bus can also be used for Service Diagnostics.

The total amount of slide cycles for the models 7020 and 9020 can be read out with the Diagnostic Software TL-4575 ("SYSTEM REPORT" menu).

The modular design, the LAMP MODULE and the accessory slot for special MODULE's are needed to adapt the Projector to future applications.

All models can be operated with 80 and 140 slide trays.

Compliance with international safety regulations has been approved.

All models are available in two versions:

- a) for 120/220/230/240 V, 50/60 Hz
- b) for 100/220V 50/60 Hz (Japan)

Projector Models

EKTAPRO Model 4020

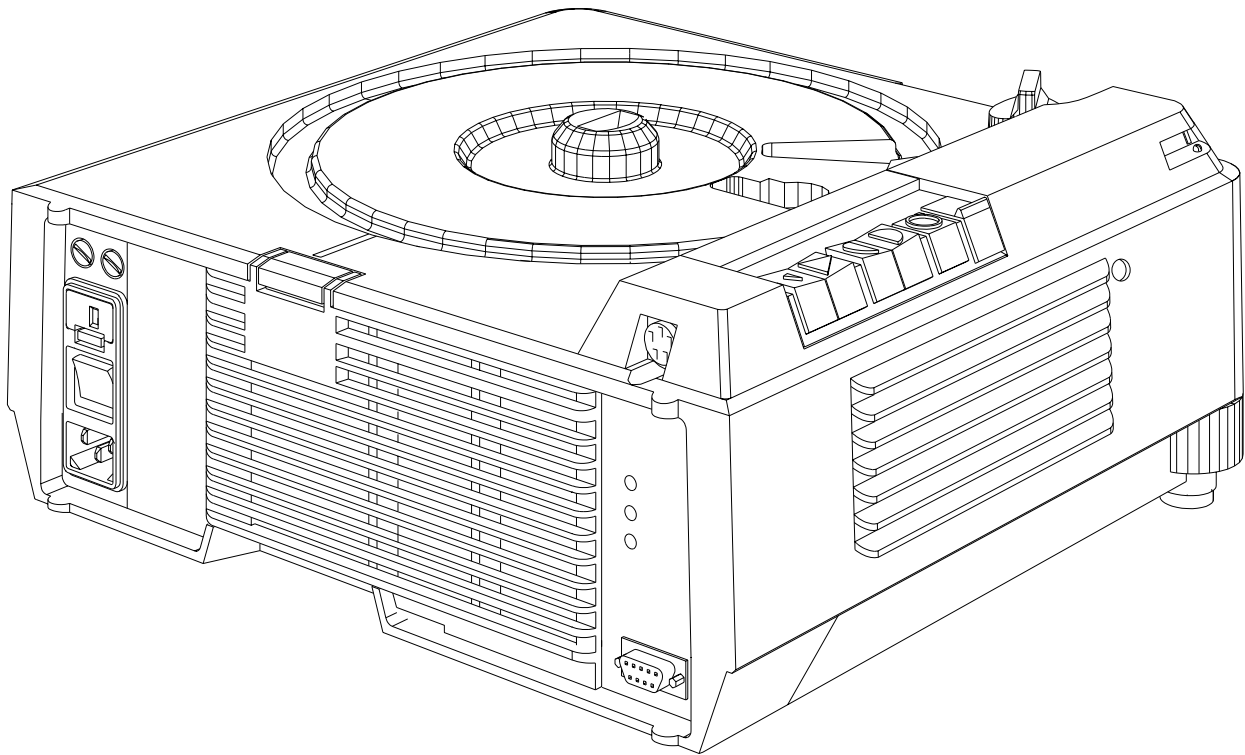

figure 2-1

Features and Functions:

Line voltages	:	120/220/230/240V or 100/220VAC can be select with an external VOLTAGE SELECTOR
Line frequency	:	50/60 Hz
Power consumption	:	380 W
Dual Lamp Module		
Extra Bright:		
	:	35h EXR 82V/300 W
	:	70h FHS 82V/300W
	:	200h EXY 82V/250W
Slide change time	:	approx. 0,9s (single step)
	:	approx. up to 3s (random access)
Focus	:	Manual and electrically
Standby function	:	If the standby mode is activated the Keyboard will be disabled
Economy LAMP setting	:	75% light output
No SLIDE No LIGHT function:		Using an IR REMOTE CONTROL the keycode 550* will disable this function, enter of the same keycode enables this function again
Slide Tray capability	:	80/140 slides
Slide Tray Switch	:	After changing the switch position the Projector is running automatically through a initialization procedure

EKTAPRO Model 4020

Adjustable Tray Motion	:	Tool PN 622 0454 has to used on Projectors from SN 85 xxx and above
Manual elevator mechanism	:	Two height adjustment feet are attached on the front side of the Projector
Indicator LED on front	:	LED continuously on Projector O.K. If the LED is blinking fast a slide jam occurs. In standby mode the LED is blinking short off and long on. If the LED is blinking continuously (on/off) a checksum error occurs (only during programming the processor)
Remote SOCKET	:	8 pin mini DIN
Slide change buttons	:	A single step will happen after pressing the "Forward" or the "Reverse" button less than 0.9s. Multiple steps will be done by pressing the "Forward" button more than 0.9s A run into the "Zero" position will immediately be done after press and hold the "Reverse" button until the Slide Tray is in "Zero" position
Last Lamp used	:	After switching on the Projector the last used lamp will be selected (memory function). This memory function can be disabled by pressing the STANDBY button during switching on the projector
Line up	:	Pressing both transport keys will enable the lamp to adjust the projector (green LED on the Backpanel is blinking). The Standby key will disable this function

NEW

In case of using a IR Remote Control single steps are possible independent how long the button is pressed.

By pressing the "Reverse button" on the IR Remote Control random access is possible.

To select the Slide Tray capacity (80 or 140 slides) a ball point pen or a small screwdriver has to be used.

The Lamp Module has no longer a Heat Absorbing Glass installed. Due to the new mirror the light output is increased up to 30%.

NOTE

In case of changing the mirror take care of the type (see NEWSLETTER #4).

EKTAPRO Model 5020

figure 2-2

Features and Functions:

All features and functions of Model 4020

Additional:

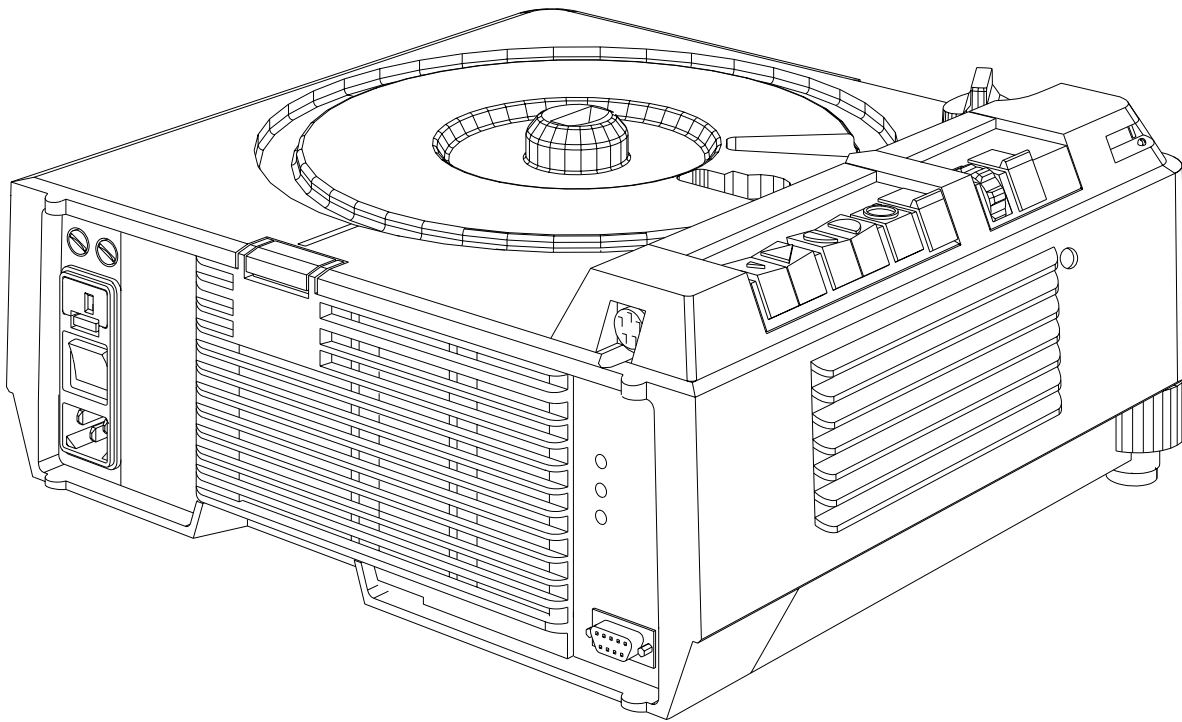
- | | | |
|------------|---|--|
| AUTO FOCUS | : | Each slide will be focused, independent of the slide mount |
| Timer | : | Slide change can be set from 1 up to 60 sec. |

EKTAPRO Model 7020

figure 2-3

Features and Functions:

All features and functions as Model 4020.

Additional features:

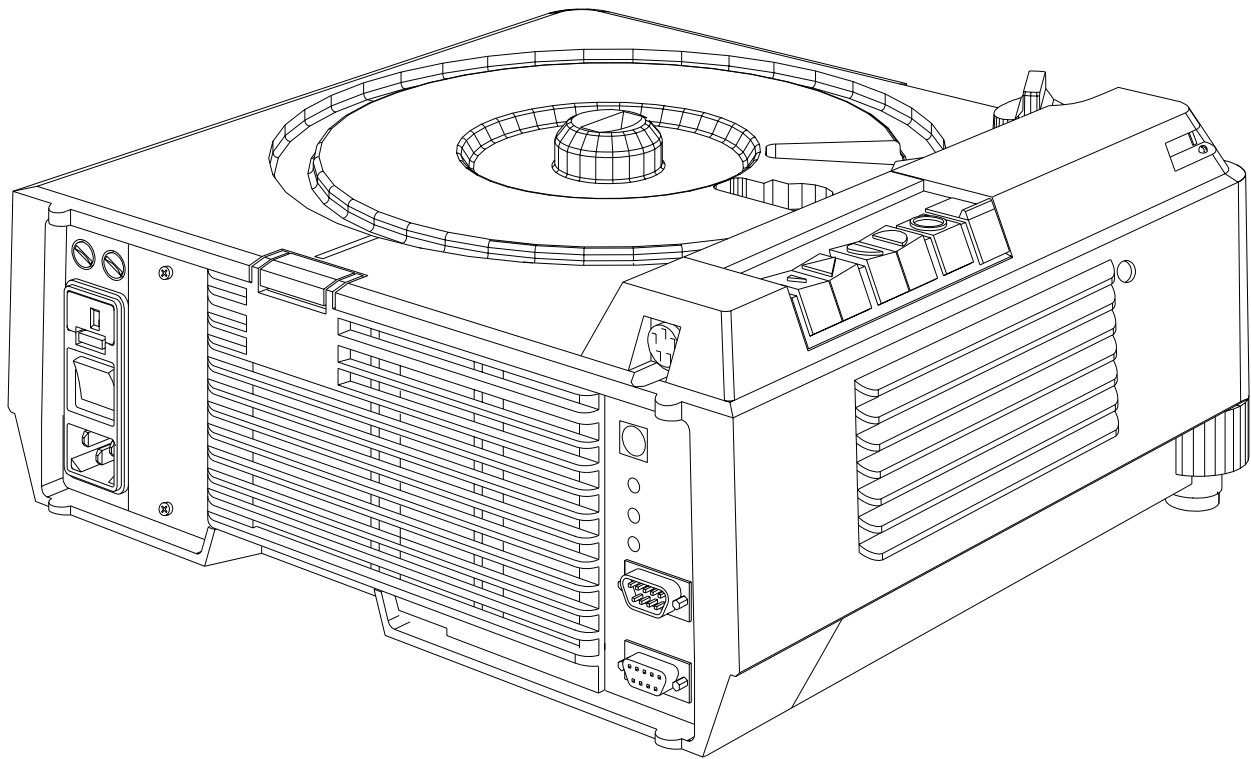
Application Slot	:	for Kodak and OEM ADAPTERS
Bus CONNECTORS (RS232):	:	IN (female) and OUT (male)
Address Switch	:	16 addresses can be selected
Initializing procedure	:	After power on the Projector the SLIDE LIFTER and the RING DRIVE will be checked, the LAMP and the FAN will be switched off
High Light	:	20% more light output, lamp life time approx. 30% reduced

NEW (only on Models 7020/9020)

If the parallel Mode "970*" is set on the IR Remote Control it is possible to toggle with "666*" between two projectors to control the focus functions. These functions are only visible on the screen.

EKTAPRO Model 9020

figure 2-4

Features and Functions:

This multi purpose Projector has all of the features of the EKTAPRO 7020.

Additional features include:

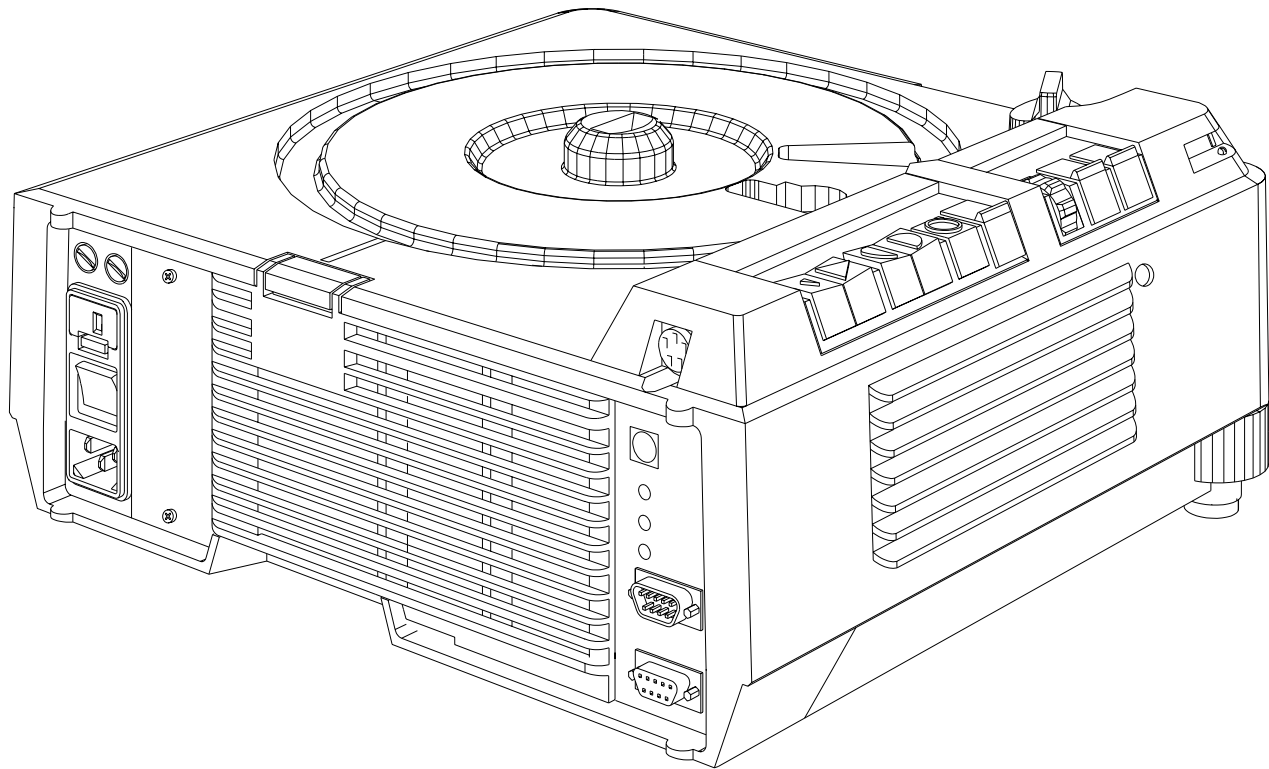
- | | | |
|---------------------|---|--|
| AUTO-ZERO function: | : | When the Projector senses an empty, gate the Projector automatically returns the tray to zero and begins the projection cycle again. This function can be deenergized. |
| Timer | : | Slide change can be set from 1 up to 60 sec. |
| AUTO FOCUS | : | Same as in EKTAPRO 5020 |
| High Light | : | 20% more light output, lamp life time approx. 30% reduced |

NOTE (new Model EKTAPRO 920/CINE)

For special applications (cinema promotion) the Model EKTAPRO 920/CINE is available. This model has a build in memory function which knows the last projected slide after switching off the projector.

Switching the projector on again the slide tray will run into that position after the initialization procedure.

If the timer is switched on at that time a soft dissolve will be started immediately.

New parts (NAMEPLATE and MICROCONTROLLER) see Illustrated parts list.

Overview

FUNCTIONS/ACCESSORIES	Model			
	4020	5020	7020	9020
DUAL LAMP MODULE (Extra BRIGHT)	X	X	X	X
TIMER	-	X	-	X
AUTO-ZERO	-	-	-	X
ADDRESS SWITCH	-	-	X	X
APPLICATION SLOT	-	-	X	X
AUTO FOCUS	-	X	-	X
PRESENTATION BUS "IN"	X	X	X	X
PRESENTATION BUS "OUT"	-	-	X	X
RANDOM ACCESS	X	X	X	X
EXTERNAL DIAGNOSTICS	X	X	X	X
12/7-PIN MODULE	-	-	O	O
SLIDE SYNCHRONIZER (1000Hz)	-	-	O	O
TWIN SOCKET	O	O	O	O
CABLE REMOTE	O	O	O	O
IR REMOTE SYSTEM RA	O	O	O	O
IR REMOTE SYSTEM RA/LP	O	O	O	O

X = Standard Feature O = Accessory - not possible

Accessories

DUAL LAMP MODULE

CAT No. 718 4369

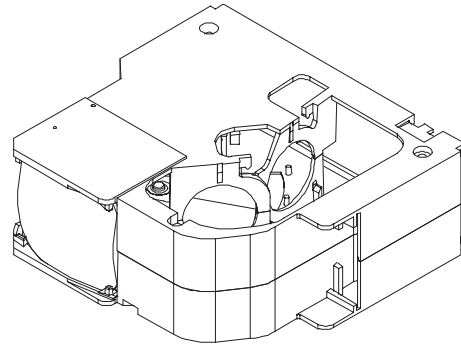

figure 2-5

CABLE REMOTE

CAT No. 712 1080

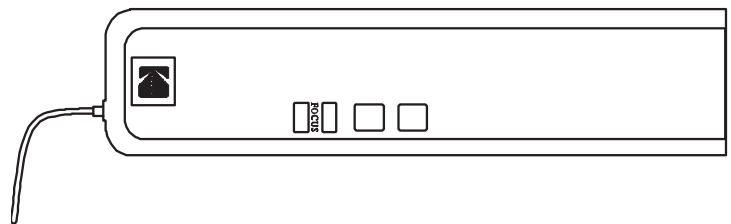

figure 2-6

HEAT ABSORBING GLASS with CLIP

(not installed in Model 3020)

CAT No. 717 7140 (6mm thick)

CAT No. 717 7157 (3mm thick)

see NEWSLETTER #3/MAY/1996 page 5

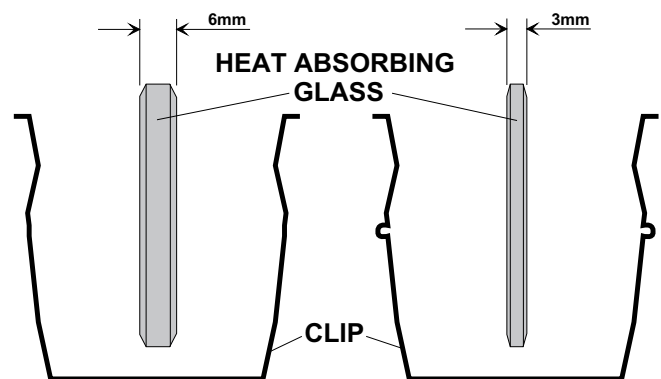

figure 2-7

CONDENSER KIT 4X4 (with CLIP)

CAT No. 714 4967

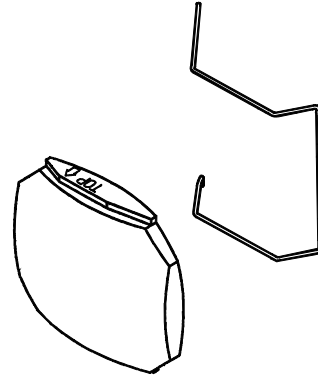

figure 2-8

IR REMOTE System RA (with Random Access)

CAT No. 712 1072

complete with RECEIVER and TRANSMITTER

RECEIVER

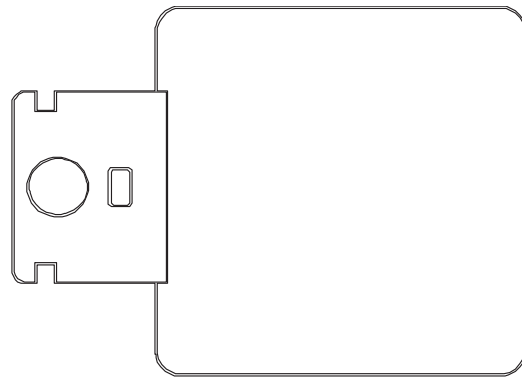

figure 2-9

TRANSMITTER

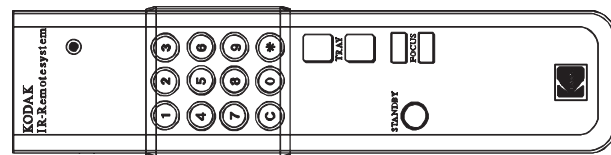

figure 2-10

IR REMOTE System RA/LP (Laser Pointer)

CAT No. 712 1064 complete with RECEIVER

TRANSMITTER

RECEIVER as use with IR REMOTE System RA.

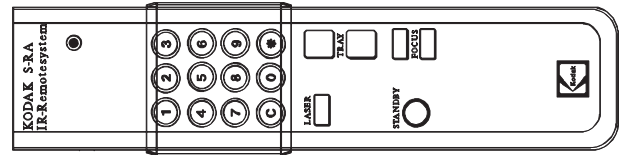

figure 2-11

12/7-PIN MODULE

CAT No. 712 5875

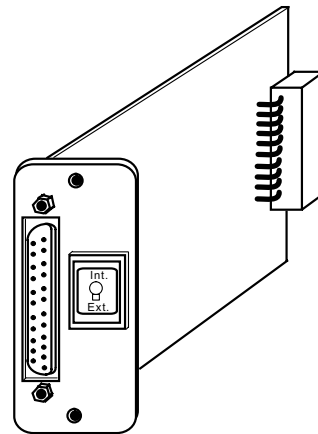

figure 2-12

LENS SUPPORT

CAT No. 715 1335

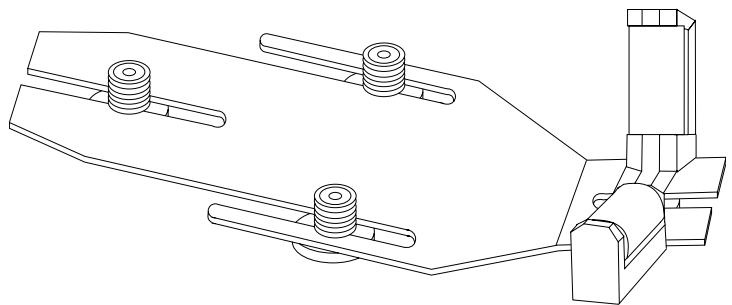

figure 2-13

12/7-PIN ADAPTER CABLE

CAT No. 712 5883

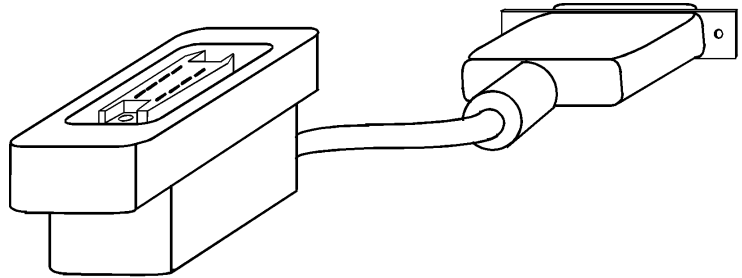

figure 2-14

TWIN SOCKET ADAPTER

CAT No. 712 5909

see NEWSLETTER #3/MAY/1996 page 7

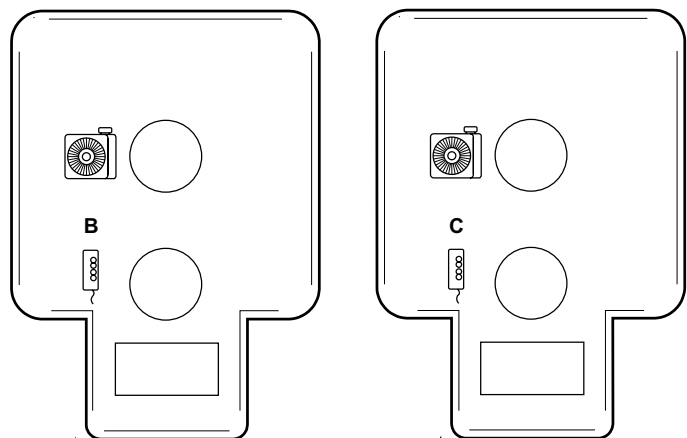

figure 2-15

SLIDE SYNCHRONIZER

CAT No. 712 5891 (not available)

see page 16 OEM ACCESSORIES

LAMPS

Catalog No.	Description	Lifetime
145 2259	EXR 82V/300 W	life time about 35 hours
147 7678	EHS 82V/300 W	life time about 70 hours
145 2143	EXY 82V/250 W	life time about 200 hours

Specification

Electrical Supply	:	120/220/230/240 V
	:	or 100/220 V
	:	50/60 Hz
Power Consumption	:	380 W
Dimensions	:	310 x 355 x 145 mm max. (l/w/h) with tray and lens (12.2 x 14 x 5.7 in)
Weight	:	6300 g (13.9 lb)
Slide size	:	24 x 36 mm (0.9 x 1.4 in)
Slide change time	:	<0,8 s
Slide search time	:	<3 s
Slide temperature	:	50°C (104°F) max. above room temperature
LAMP (standard)	:	EXR 82V/300W
Automatic LAMP change	:	0.3 s
Operating temperature	:	0°C to 40°C (32°F to 113°F)
Humidity	:	20 to 85% r.H.
Air consumption	:	approx. 700 l/min. (20,000 cuft/min.)
Approvals	:	VDE, UL , CSA
Leveling	:	0° to 18° with internal elevation mechanism 30° max. allowed

CONNECTORS

Remote SOCKET on Projector:

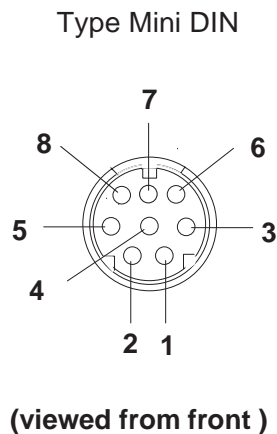

PIN No.	Signal
1	12 VDC
2	Gnd
3	Signal 1 (LSB)
4	Signal 2
5	Signal 3
6	Signal 4
7	Signal 5 (MSB)
8	Interrupt

12 V DC =
average value between 7.2 and 14.5 V DC

figure 2-16

P-Bus / RS 232 “IN”

D-SUB 9-pin connector female

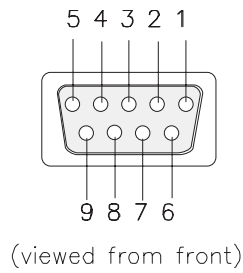

PIN No.	Signal
1	Connected to 4 and 6
2	Receive Data (RxD)
3	Transmit Data (TxD)
4	Connected to 1 and 6
5	Signal Ground
6	Connected to 1 and 4
7	-
8	-
9	-

figure 2-17

P-Bus / RS 232 “OUT”

D-SUB 9-pin connector male

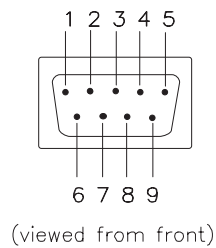

PIN No.	Signal
1	Connected to 4 and 6
2	Transmit Data (TxD)v
3	Receive Date (RxD)
4	Connected to 1 and 6
5	Signal Ground
6	Connected to 1 and 4
7	-
8	-
9	-

figure 2-18

ACCESSORY SLOT

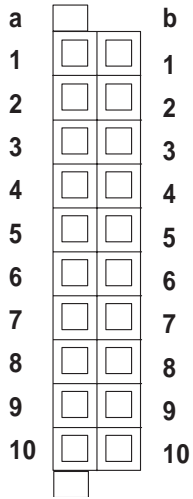

figure 2-19

PIN No.	Signal
a 1	SDA (I ² C Data)
a 2	I ² C_INT (Interrupt)
a 3	SLOT_232_R, TTL Level
a 4	not used
a 5	SLOT_A
a 6	SLOT_C
a 7	not used
a 8	12V DC 200mA max.
a 9	34V DC 750mA max.
a 10	26V AC_N 750mA max.
b 1	SLC (I ² C Clock)
b 2	PLL_DISS
b 3	SLOT_232_T (TTL-Level)
b 4	SLOT_DIS
b 5	SLOT_B
b 6	SL_DISS
b 7	not used
b 8	VSS 12 (Ground)
b 9	VSS 34 (Ground)
b 10	26V AC_L

OEM ACCESSORIES

COPYRIGHT

The adapter of this English company is only designed to use traditional AV cassette recorders. Cue pulses recorded on the tape trigger the interface unit to generate digital commands to advance the EKTAPRO Projector. It is an interesting feature that the adapter works either by plugging directly into the remote socket or works remotely by additional use of the EKTAPRO IR Receiver. In this case the system can simultaneously used with both the EKTAPRO IR Transmitter and the adapter. The adapter is powered by a 9 volt A PP3 battery.

The illustration (figure 2-20) shows both possibilities to run the Projectors.

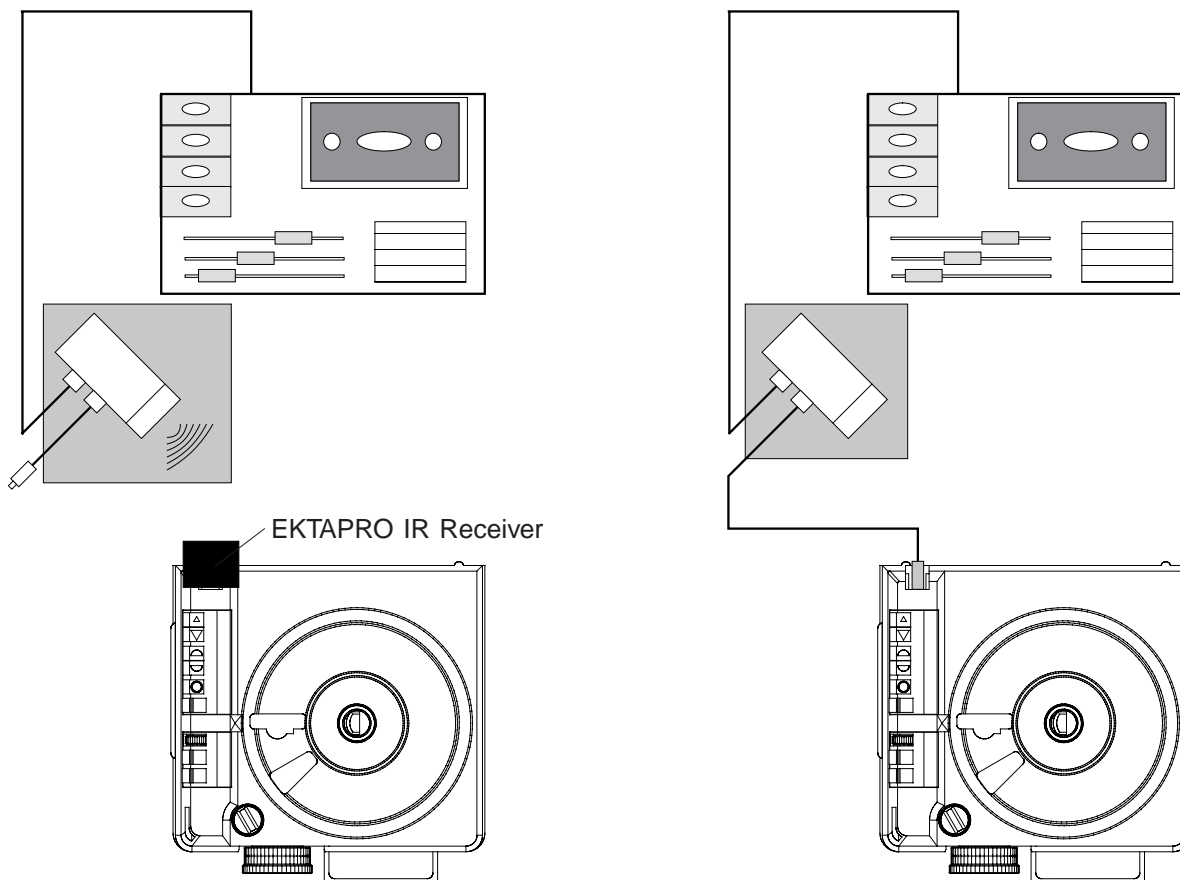

figure 2-20

IR-USE.

The advantage is that the Adapter and Projector can be separated. In addition, the use of the EKTAPRO Remote Transmitter is possible without disconnecting the Adapter.

CABLE USE

If no IR receiver is available the Adapter can be plugged with the fixed installed cable to the remote socket.

SLIDE SYNCHRONIZER ADAPTER by KODAK AUSTRALIA

Kodak Australia offers an own solution of a slide synchronizer adapter. This unit is built in the IR Receiver housing and is therefor directly to be plugged onto the remote socket. A 6pin socket is built into the housing. The system supports most of traditional AV cassette recorders. The S-AV cable remote can also be used with the possibility to give transport commands and to focus. Speaker desk (lecterns) installations can be fully used. The system is able to switch the Projector into the standby mode (press forward and reverse button simultaneously) or run to the Projector to the zero position (press and hold down forward and reverse button).

NOTE

The S-AV Timer does not work on this adapter!

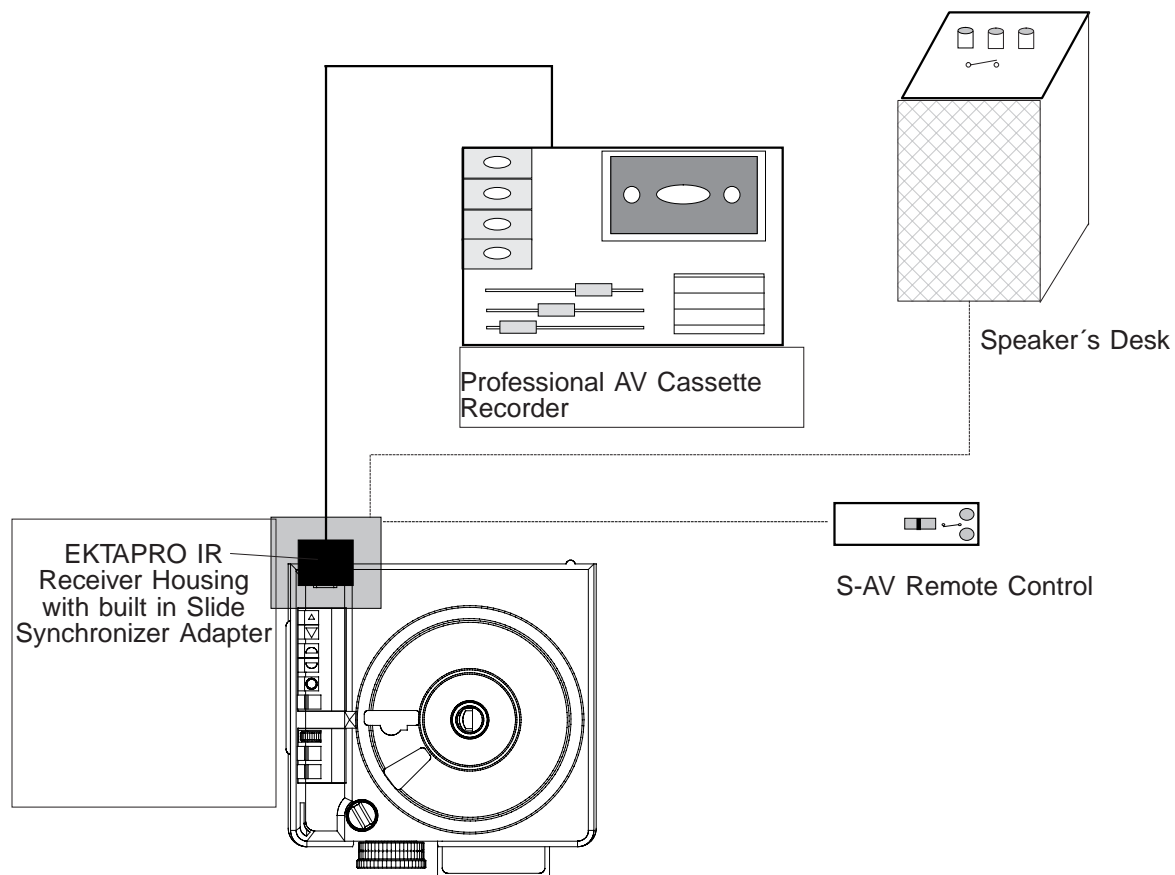

figure 2-21

ADAPTER by MÜWO

The German company offers a slide synchronizer adapter which is built into the EKTAPRO Cable Remote Control. A 6pin socket provides connection with external devices which are traditional AV cassette recorders, S-AV Timer and speaker desks. Even if any devices are connected, the remote still works.

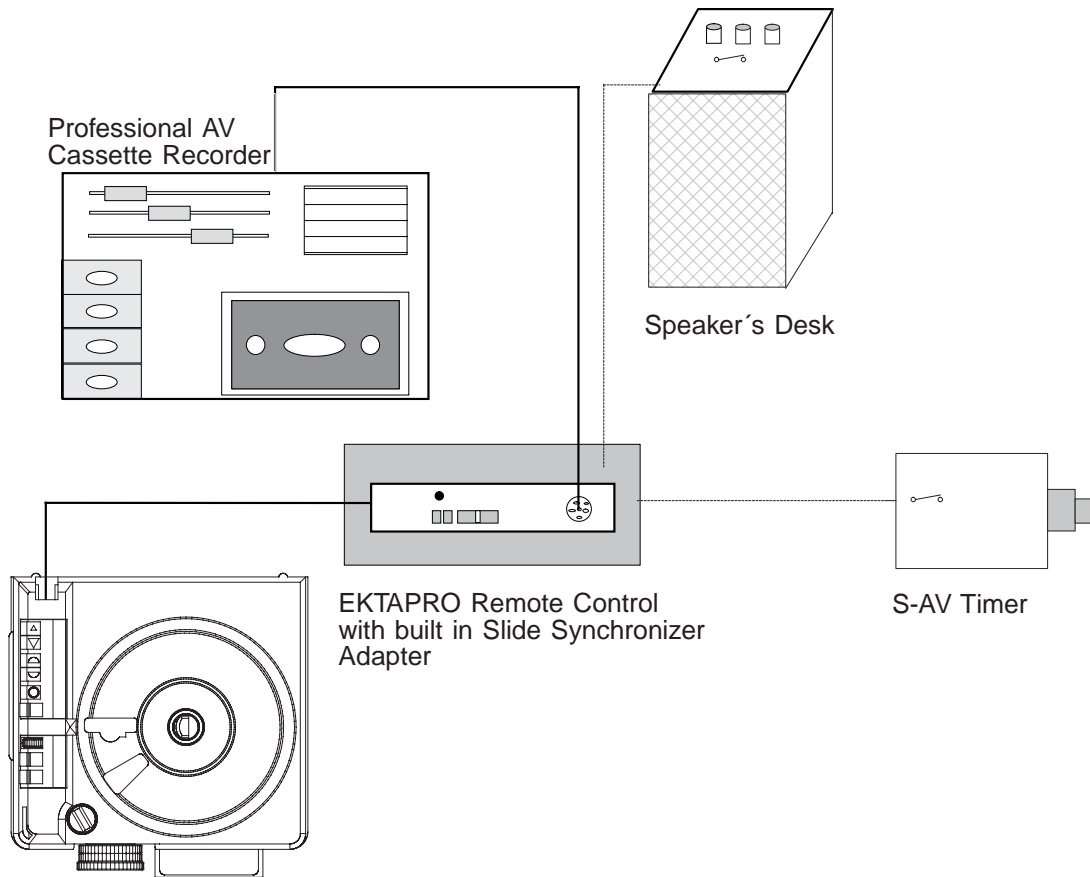

figure 2-22

ADAPTERS by MAYER & ZELLER

The Swiss company Mayer & Zeller offers a 1000 Hz adapter which comes along in a small black plastic box with a standard 6pin female receptacle and an integrated cable with the new 8pin male connector for the EKTAPRO Projectors.

The adapter offers the possibility either to connect a traditional AV cassette recorder to advance the Projector or to connect the standard cable S-AV remote control or to use the cable already installed in the speakers desks.

The adapter is also offered in a special version which also enables the control of the focus via the remote control (or speakers desks).

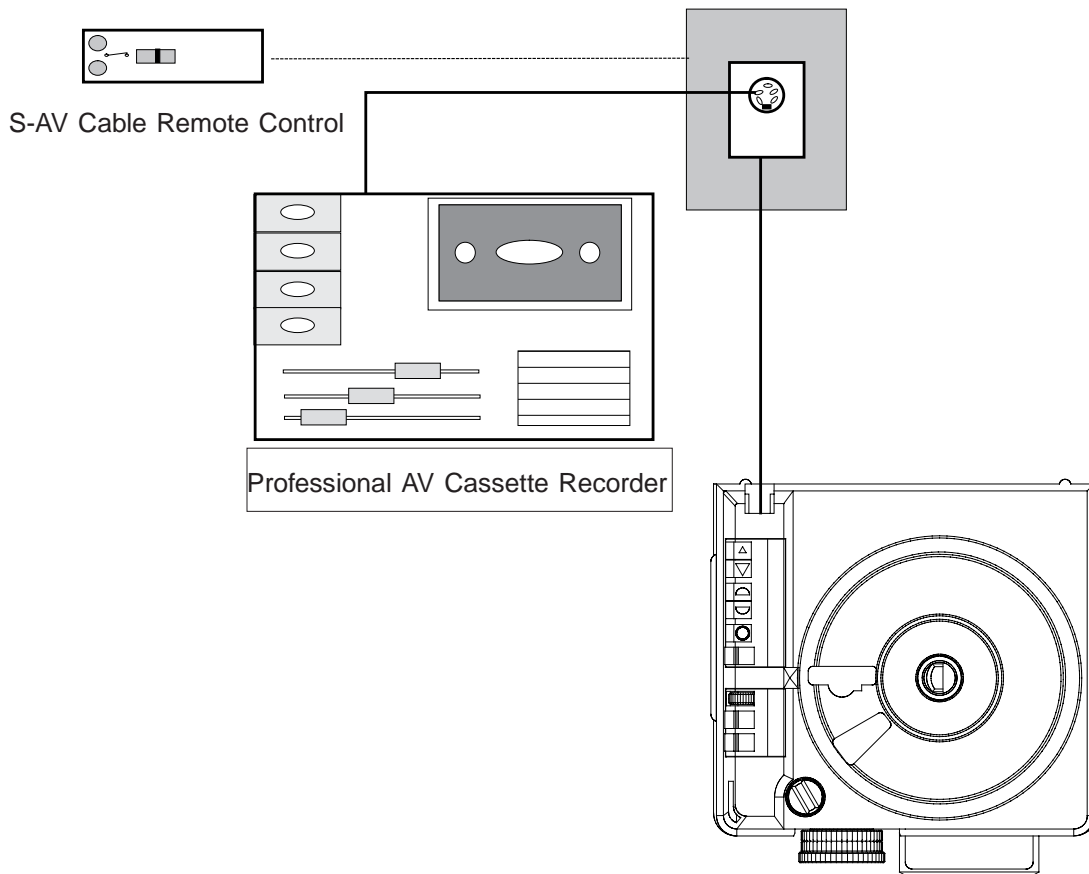

figure 2-23

NOTE

The S-AV Timer cannot be used because of the lack of a support voltage . But Mayer & Zeller offers a special Timer for controlling the EKTAPRO Projectors. The timer is built into the EKTAPRO Cable Remote Control. This a quite sophisticated solution and an interesting offer for those who intend buying a cable remote.

For further details contact the company.

ADDRESSES

CONTROL SYSTEMS

- ARION 701 South 7th Street Delano, MN 55328 USA
Tel: (001) 612 972 3351
Fax: (001) 612 972 3524
- Bässgen AV Technik GmbH Hauptstraße 58, 79104 Freiburg Germany
Tel: (0049) 761 23953
Fax: (0049) 761 35042
- Copyright Machines Limited 44/46 Sillwood Street Brighton, Sussex BN1 2PS UK
Tel: (0044) 273 720 175
Fax: (0044) 273 321 150
- Dataton AB Box 257 S-581 02 Linköping Schweden
Tel: (0046) 131 14325
Fax: (0046) 131 38445
- HEP Holland P.O.B. 33112, 3005 EC Rotterdam Niederlande
Tel: (0043) 10 418 3689
- Mechanische Weberei GmbH Neuhäuser Weg 2, 33175 Bad Lippspringe Germany
Tel: (0049) 52 52270
Fax: (0049) 52 522 7201
- Müwo electronic In den Maltwiesen 11, 72379 Hechingen-Stetten Germany
Tel: (0049) 7471 15830
- RMF Products Inc. P.O.B. 520, 1275 Paramount PKWY Batavia II, 60510 USA
Tel: (001) 708 879 0020
Fax: (001) 708 879 6749
- Stumpfl Rudigierstraße 8, A-4701 Bad Schallerbach Austria
Tel: (0043) 7249 2811
Fax: (0043) 7249 2811 18
- Zygo Systems Limited 48 Fallowfields Bicester Oxon OX67Qs UK
Tel: (0044) 869 248 261
Fax: (0044) 869 248 260

SOFTWARE for direct PC CONTROL

- ARION 701 South 7th Street Delano, MN 55328 USA
Tel: (001) 612 972 3351
Fax: (001) 612 972 3524
- AVC Team Bieber Am Holling 3, 35649 Bischoffen Germany
Tel: (0049) 6444 1027
Fax: (0049) 6444 8527
- Martin Ballein Viktor Scheffel Straße 2, 74076 Heilbronn Germany
Tel: (0049) 7131 165170
Fax: (0049) 7131 52470
- Hilger & Bremen GbR Heinzenstraße 20, 52062 Aachen Germany
Tel: (0049) 241 49797
Fax: (0049) 241 49787
- Holidays Afloat Limited Schachterij 9920 Lovendegem Belgium
Tel: (0032) 9372 8908
Fax: (0032) 9233 5609
- Stumpfl Rudigierstraße 8, A-4701 Bad Schallerbach Austria
Tel: (0043) 7249 2811
Fax: (0043) 7249 2811 18
- Peter Ziegler Van Gogh Platz 6, 53844 Troisdorf Germany
Tel: (0049) 2241 46143

RACKS

- Chief Manufacturing Inc. 14310 Ewing Avenue South Burnsville MN 55337 USA
- Roha Projektionstechnik Bruno Jacoby Weg 11, 70597 Stuttgart Germany
Tel: (0049) 711 723 621
Fax: (0049) 711 23699

EXTERNAL TIMER

- Mayer & Zeller Wettsteinallee 15, 4058 Basel Switzerland
Tel: (0041) 61681 4343
Fax: (0041) 61681 3907
- Müwo electronic In den Maltwiesen 11, 72379 Hechingen-Stetten Germany
Tel: (0049) 7471 15830
- Wintron GmbH Egilolfstraße 70, 70599 Stuttgart Germany
Tel: (0049) 711 4567 258
Fax (0049) 711 4567 267

blank page

3. THEORY GUIDE

Block Diagram

All functions of the projector are controlled by the MICROCONTROLLER (MC68HC016B with 16k ROM) on the MASTER PCB.

The controlling software is loaded in the 16k ROM of the MICROCONTROLLER for Models 4020 - 9020 and 9020/CINE.

Located around the MICROCONTROLLER on the MASTER PCB there are the inputs, outputs and drivers for the sensors, LAMP, MOTOR's and other functions.

The block diagram (figure 3-1) shows all of the functions of Model 7020 and 9020.

All model is equipped with the same MASTER PCB's.

MODEL	MASTERBOARD	MICROCONTROLLER
4020	LAYOUT No.7	Version 4.8
5020	LAYOUT No.7	Version 4.8
7020	LAYOUT No.7	Version 4.8
9020	LAYOUT No.7	Version 4.8
9020/CINE	LAYOUT No.7	Version 4.9

MASTERBOARD Model 4020 - 9020 (9020/CINE)

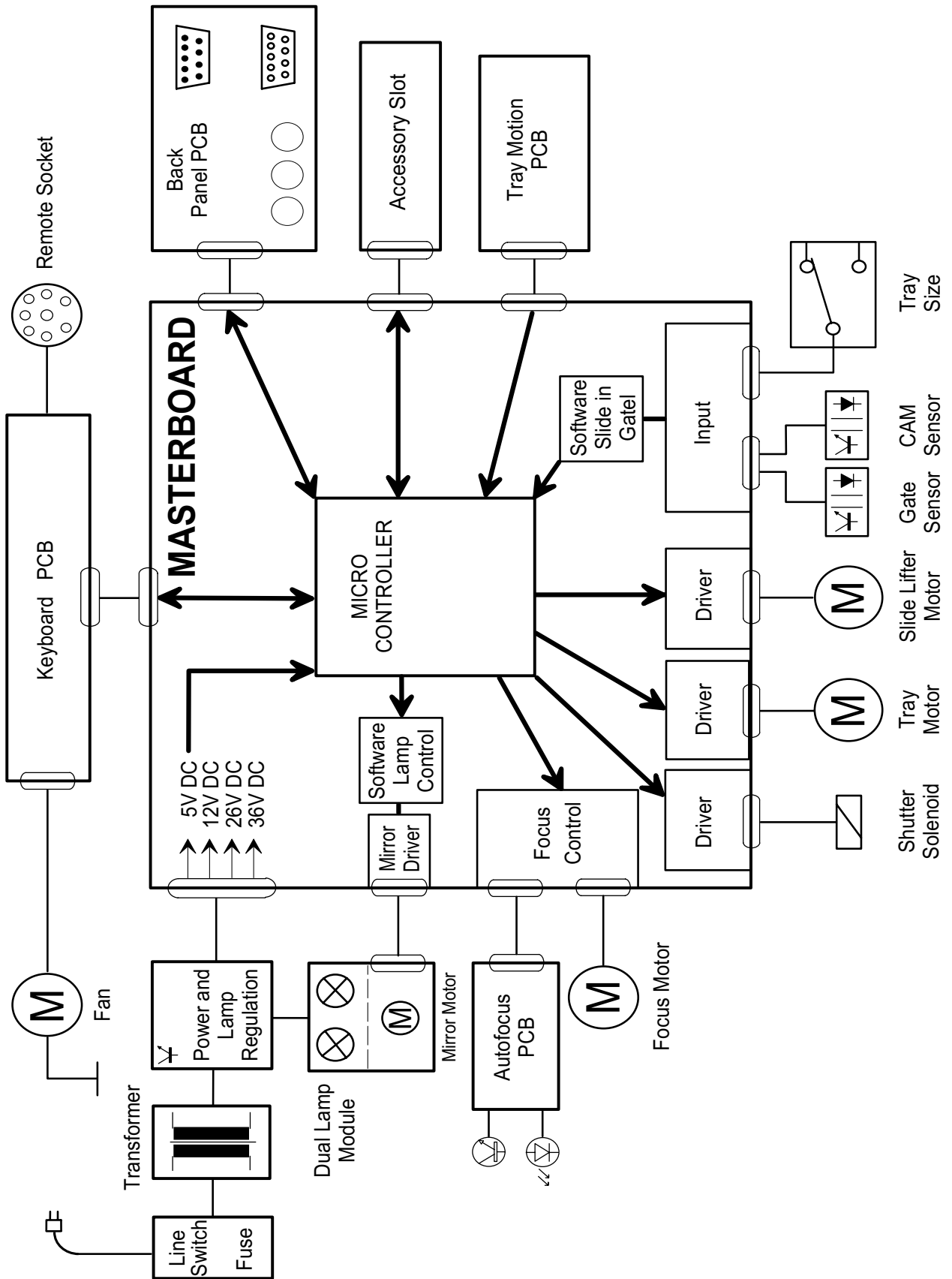

figure 3-1

Microcontroller Unit

The main device on the MASTER PCB is the 16-bit MICROCONTROLLER unit MC68HC05B16 from *MOTORola* for the models EKTAPRO 4020 - 9020 and 9029/CINE

This MICROCONTROLLER has a microprocessor, timer, memory, analog/ digital converter and input/output ports on one chip. Compared to a standard processor, where for each item a peripheral IC is necessary.

This MICROCONTROLLER with its on-chip software controls all functions of the projector plus peripheral circuits.

The main features of the MICROCONTROLLER are:

- 24 bi-directional I/O lines
- 8 input-only lines
- serial communication interface system
- 8 channel A/D converter
- 15120 Bytes ROM (Models 4020 - 9020 and 9020/CINE)
- 2 channel timer

The following block diagram shows the internal MICROCONTROLLER functions.

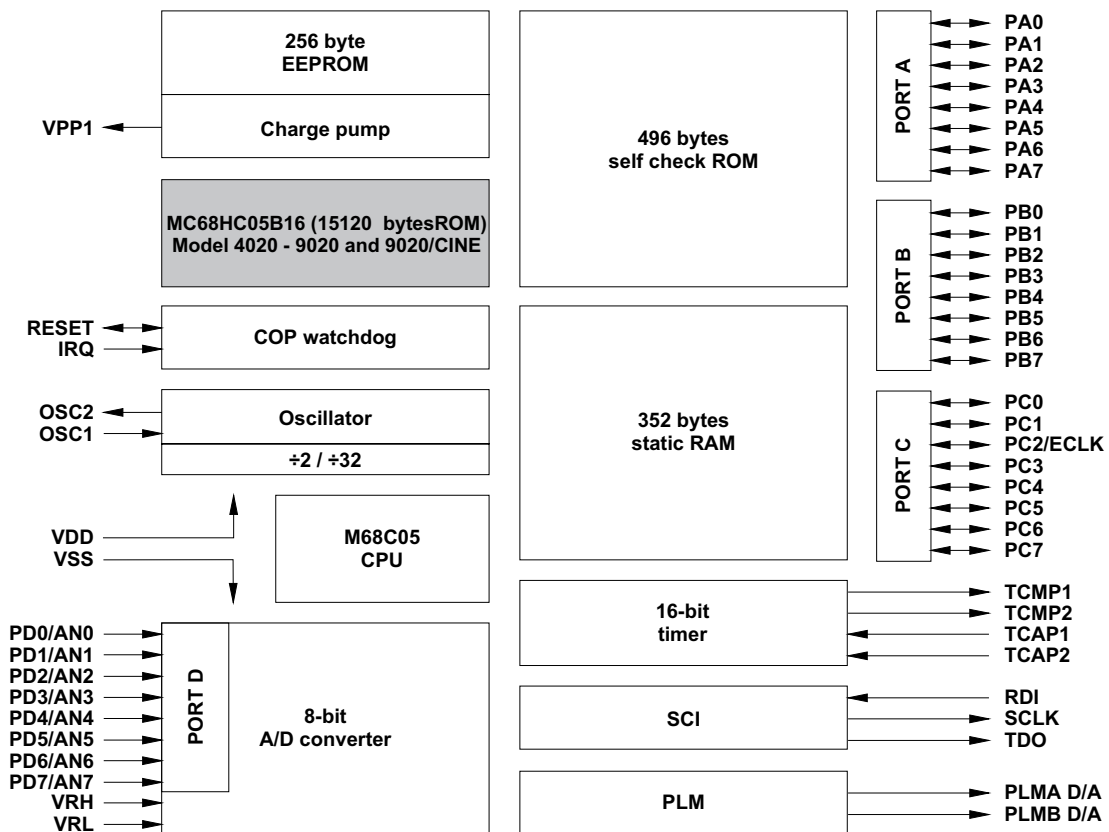

figure 3-2

Description of Functions

Power Supply

The PROJECTOR POWER SYSTEM consists of a

- POWER INPUT ASSEMBLY with POWER ON/OFF SWITCH, PRIMARY FUSE HOLDER and VOLTAGE SELECTOR
- TRANSFORMER, SECONDARY FUSE HOLDER
- POWER REGULATION PCB

The TRANSFORMER supplies the following voltages:

Primary voltage outputs:

92/81 VAC LAMP voltage for Models 4020 - 9020 and 9020/CINE (SOFTWARE CONTROLLED LAMP CURVE)

Safety Extra Low Voltage outputs:

10 VAC for +5V DC and +12V DC
26 VAC for 36 VDC regulated and unregulated,

The POWER REGULATION PCB contains:

- line EMI filter
- rectifiers and regulators
- Triac LAMP Software Control Circuits (Models 4020 - 9020 and 9020/CINE)

The output voltages and signal are:

- 36 VDC unstabilized (36 VDC_12P) for slot interface
- 36 VDC capacitor- stabilized (36 VDC) for MOTOR's, solenoid, fan
- 12 VDC unregulated for remote control and slot
- 5 VDC regulated for logic and MICROCONTROLLER
- 26 VAC for accessory slot
- Zero_cross signal for synchronization of the dissolve feature

Details can be obtained from circuit diagrams and the following block diagram.

IMPORTANT

Connect all the equipment to the same same power line, otherwise phase shifting will bring up problems !

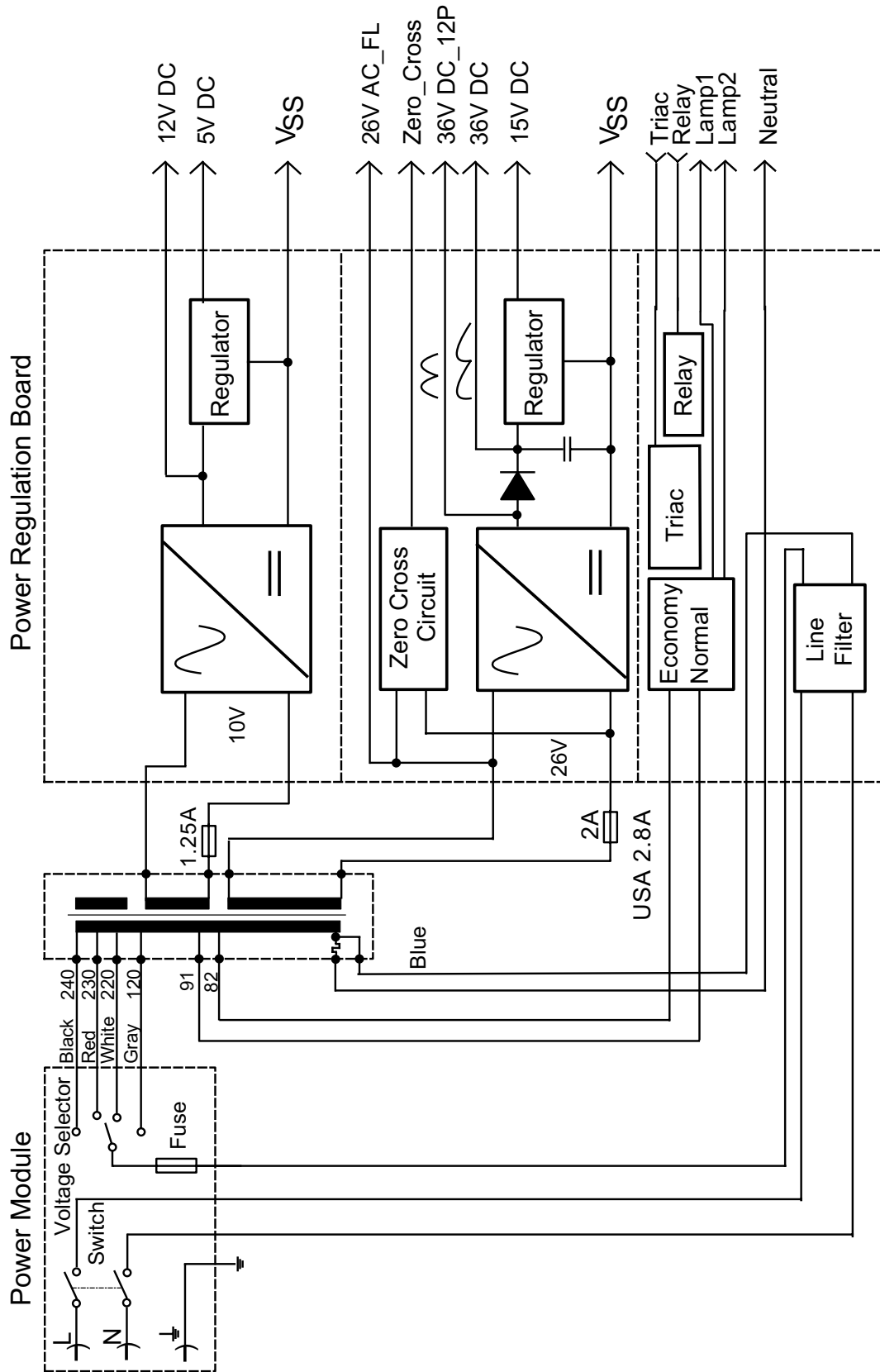

figure 3-3

Switch On / Initialize Procedure

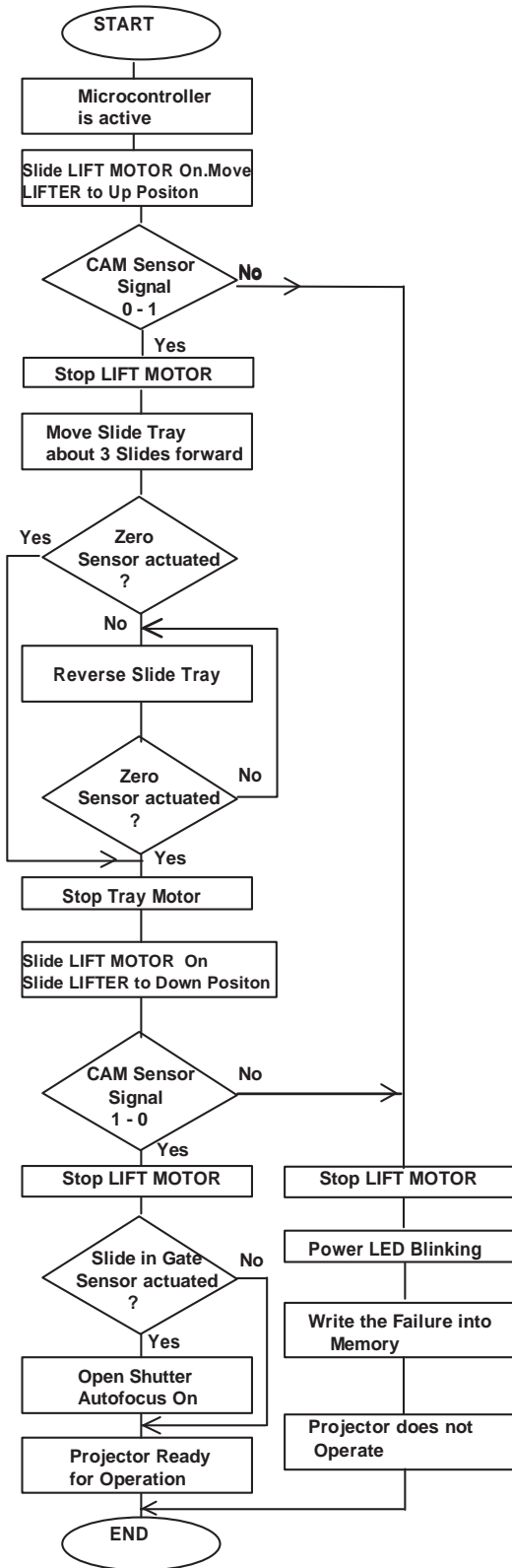

figure 3-4

Projector Status: Mechanic position is not known
Projector is energized

The MICROCONTROLLER starts the initialization routine:

- load the look-up tables
- look at the accessory slot and projector address
- sets the ECONOMY LAMP RELAY to 82V
- completes a Hardware reset

SLIDE LIFT MOTOR rotates clockwise (max. of 805 steps = one SLIDE LIFTER cycle).

If SENSOR SIGNAL changes from not actuated to actuated, the SLIDE LIFTER is in up position.

Yes = Start tray MOTION.

No = Begin a failure routine, after it has advanced 805 steps without sensor signal change.

slide tray moves forward about 3,5 slides (with software version above 4.2).

Details about tray motion can be obtain from page 3-9.

If the ZERO SENSOR is not actuated, the tray reverses

If the ZERO SENSOR is not actuated, the slide tray continues to advance.

The SLIDE LIFT MOTOR moves clockwise.

When the CAM SENSOR changes from actuated to not actuated, the LIFTER is in the down position.

If the SLIDE IN GATE SENSOR is actuated, the SHUTTER opens.

Slide Change Sequence

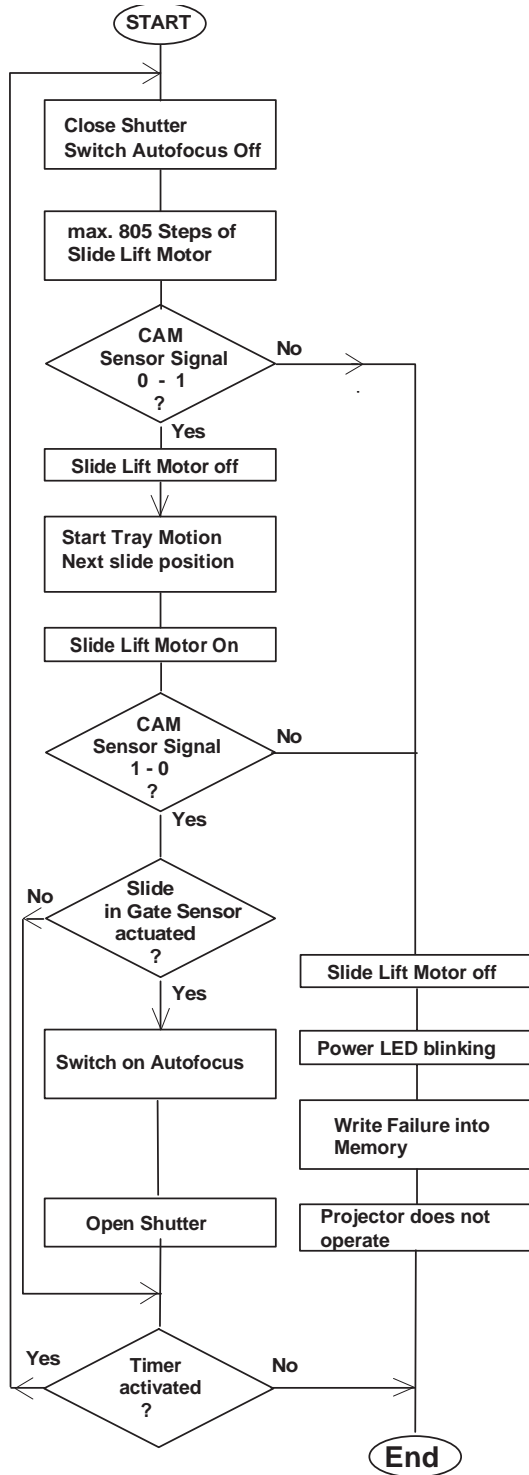

figure 3-5

Projector Status:

- SLIDE LIFTER down
- SHUTTER is open
- SLIDE is in GATE
- LAMP is energized

Start: "Forward"/"Reverse" BUTTON is pressed.
Signal from: P-Bus, Remote Control or Timer

The SHUTTER SOLENOID is deenergized.

The SLIDE LIFT MOTOR rotates clockwise to move the SLIDE LIFTER up (max. 805 steps = one SLIDE LIFTER cycle).

The SLIDE LIFTER is in the up position when the CAM SENSOR signal changes from not actuated to actuated.

If no: the failure routine begins after 805 steps a without signal change.

If yes: Starts the tray Motion. See page 3-10.

For details see page 3-10.

The SLIDE LIFT MOTOR moves clockwise to move SLIDE LIFTER down. The MOTOR stops when signal changes from actuated to not actuated.

When a TIMER is in use, a slide advance forward is done each time after the selected interval is reached (Model's 4020, 7020 external timer, Model 5020, 9020 and 9020/CINE internal timer).

The slide is projected.

Tray Motion

The STEPPER MOTOR is responsible for the slide tray movement. To move the tray one slide forward or reverse 47 steps are necessary in case a tray for 80 slides is used and 27 steps in case a tray for 140 slides is used.

The tray movement is controlled by the TRAY MOTION CONTROL PCB. This PCB contains two optical sensors, one for the code wheel and one for the Zero Position Gear.

This PCB is sending following feedback signals to the MICROCONTROLLER:

- Tray motion direction (forward or reverse)
- One pulse for each step of the STEPPER MOTOR
- Tray zero-position signal in case the tray is in the zero position

If the STEPPER MOTOR moves one step, a pulse will be send back from the TRY MOTION PCB to the MICROCONTROLLER after the step is done.

If these pulses are missing, the MICROCONTROLLER assumes that the tray is not able move. The transport stops immediately. A failure code is written into memory, the projector do not operate, the power LED is blinking

The projector must be deenergized. The jam must be cleared. As soon as the problem is solved, the projector should operate after switching on again.

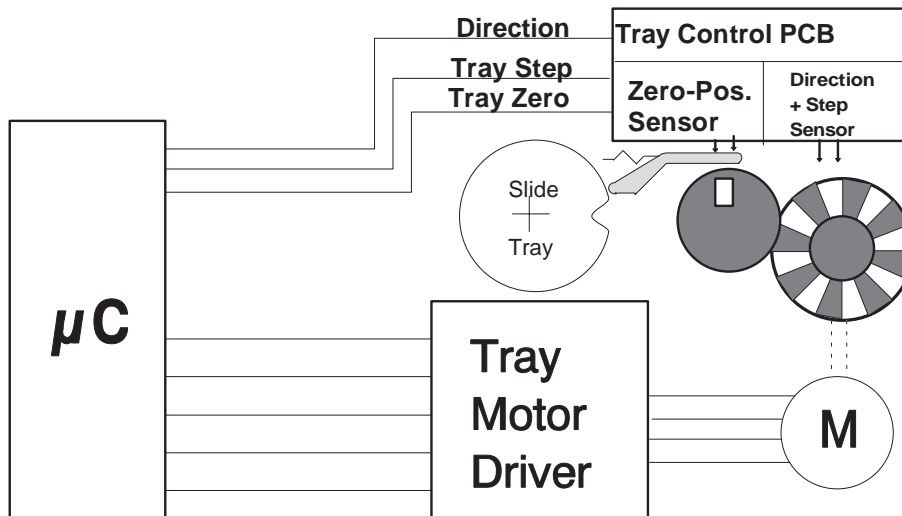

figure 3-6

The DIRECTION + STEP SENSOR is a special optical device which generates two independent output signals:

- step pulses (count signal for the MICROCONTROLLER to calculate the tray position)
- direction signal (low signal for forward steps and high signal for reverse steps)

Tray Motion Sequence:

a) Go To Zero Position

Projector Status: - Energized

Signal from: - P-Bus (Model's 4020 and 5020 input only)
 - Auto Zero (Model 9020 and 9020/CINE)

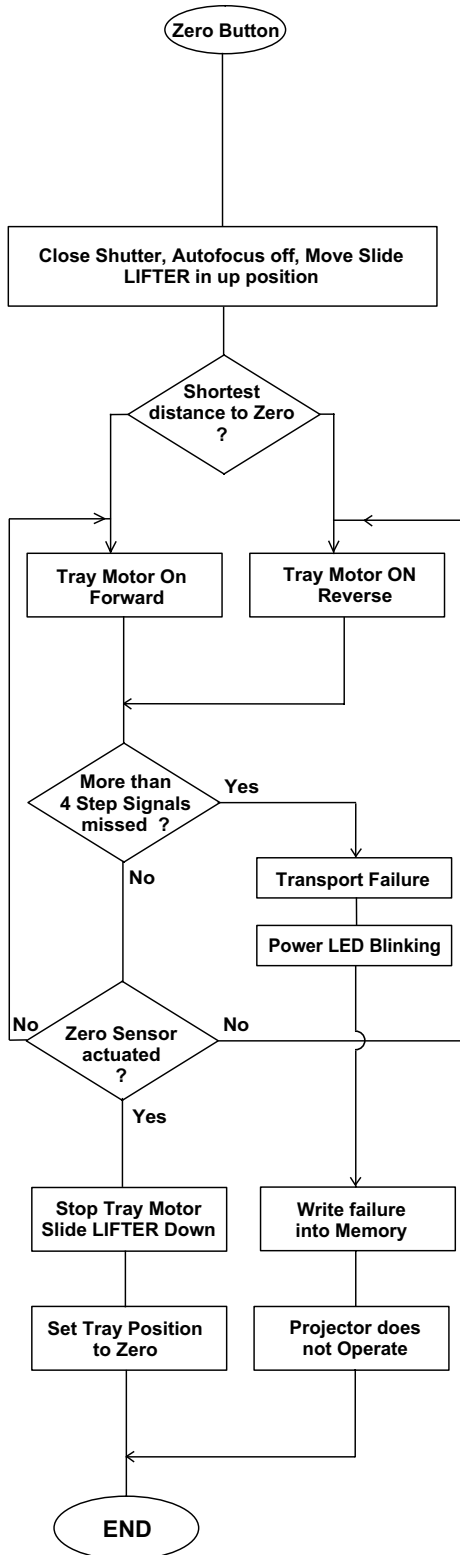

The MICROCONTROLLER selects shortest distance to the zero position.

The TRAY MOTOR is energized.

The TRAY MOTION CONTROL delivers a step signal for each MOTOR step.

The ZERO SENSOR delivers a signal if the position is reached

Failure: A failure code is written into memory.
 The power LED is blinking.

The position is reached. The TRAY POSITION in memory set to zero.

figure 3-7

b) Go to next slide position

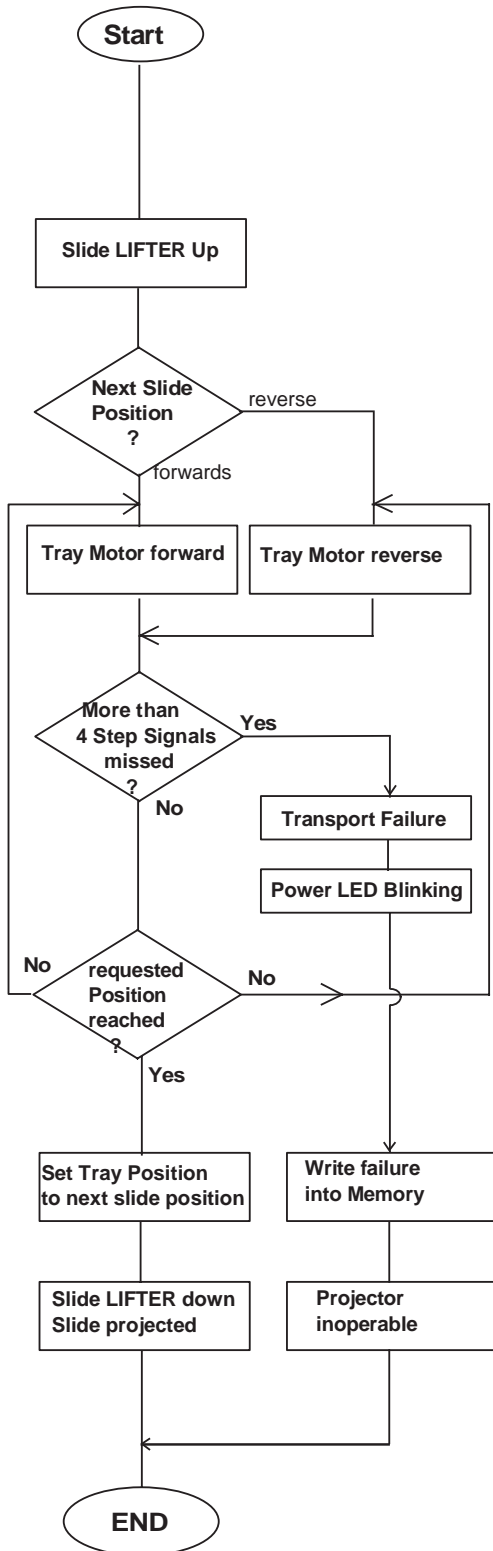

figure 3-8

Projector Status: There is a slide in the gate and it is projected.

Start action: The forward or reverse BUTTON is actuated or next slide is selected with RANDOM ACCESS.

See Slide Change Sequence, page 3-7.

RANDOM ACCESS: The MICROCONTROLLER selects shortest distance to the next slide.

The MICROCONTROLLER energizes the TRAY MOTOR for 47 steps (80 tray) or 27 (140 tray) for each slide.

The MICROCONTROLLER checks feedback from tray MOTION CONTROL CIRCUIT. If more than 4 feedback pulses are missed, exit to the failure routine.

For RANDOM ACCESS: The TRAY MOTOR ON until the position is reached.

For FORWARD/REVERSE BUTTONS:

- tray moves only for one slide
- slide is projected
- if transport button is still pressed, a slide is lifted up and the tray moves until button is released but stops at the ZERO POSITION.

The MICROCONTROLLER sets the next position into memory.

The SLIDE LIFTER Down procedure starts. For details, see Slide Change Sequence.

LAMP Control

a) Dual LAMP Operation

All Models are equipped with a DUAL LAMP MODULE (Extra Bright).

The POWER REGULATION PCB on all Models contains a LAMP current circuit that can detect if the active LAMP is on, indicated by a LED on the BACK PANEL.

If a LAMP fails, the MICROCONTROLLER receives the LAMP_CURR signal from the POWER REGULATION PCB. It activates the MIRROR MOTOR and moves the MIRROR to the second LAMP position. Then the relay K1 is energized and second LAMP is energized. The MICROCONTROLLER also energizes the LED for the second LAMP. The LED's are located on the BACK PANEL.

The Models 4020 - 9020 and 9020/CINE have a memory. This memory is storing the the current used lamp as long as the lamp is defective. That means the mirror of the DUAL LAMP MODULE do not change his position after a new lamp is inserted. This function can be disabled (see page 2-3).

The characteristic of the lamp curve is no longer generated by a PLL circuit on the MASTERBOARD. Up to now it is stored in the Software LAMP Control memory and the TRIAC will be triggered from the MICROCONTROLLER.

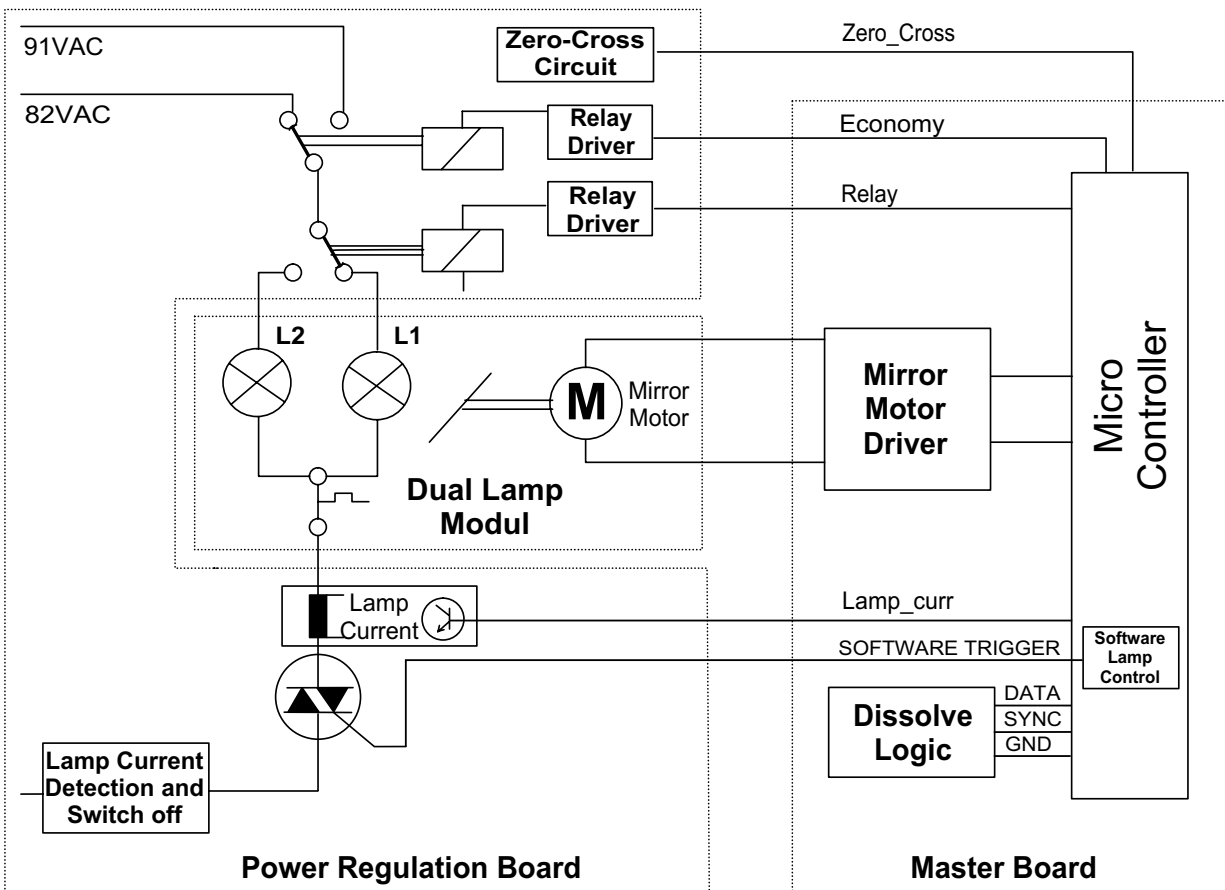

figure 3-9

b) LAMP setting

Models 4020 - 9020 and 9020/CINE:

a) Through the LAMP SWITCH or P-Bus

The settings of the LAMP are change by using the LAMP dimming function through the TRIAC DISSOLVE LOGIC. The phase cut position for LOW is 75% of HIGH .

The LAMP supply voltage is 91 VAC only.

Resulting LAMP voltages: Standard: 82V RMS
 Economy : 72V RMS

b) Via accessory slot

External units that are connected to the accessory slot cannot use the Standard/Economy LAMP setting with phase cut. Therefore, the LAMP supply voltage is switched with the ECONOMY SIGNAL and a relay to 82 VAC.

The functions of the STANDBY and Standard/Economy Buttons are disabled.

c) LAMP Protection

In the LAMP RETURN LINE on the POWER REGULATION PCB there is a small circuit that detects the actual LAMP current.

LAMPS can explode when they reach the end of their life. The melting filament can create a short circuit with a high current.

The high current is detected, and the LAMP is deenergized immediately by the TRIAC.

This procedure prevents the LAMP from exploding, and protects the TRIAC.

d) LAMP Voltage Control

All Models are equipped with a LAMP voltage regulation so that the LAMP voltage does not follow line voltage fluctuation. The 5V AC outlet of the POWER REGULATION PCB is used to create the VAC_Value signal on the MASTER PCB. This signal is fed to the MICROCONTROLLER (MC). The MC then selects a phase cut position of the LAMP voltage which results in a reasonable constant LAMP voltage. This function is disabled if an accessory is connected to the accessory slot. In this case the LAMP operates with 82 VAC.

e) Lamp Dimming

The LAMP DIMMING FUNCTION is installed in Model 4020 - 9020. It is used for dissolving for Economy and Standard LAMP settings. The main devices for dimming are the TRIAC, TRIAC CONTROL and Zero_Cross circuit on the POWER REGULATION PCB, the dissolve logic and the MICROCONTROLLER (MC) on the MASTER PCB.

The TRIAC FUNCTION is controlled by the MICROCONTROLLER and its software, it works according to phase cut principals.

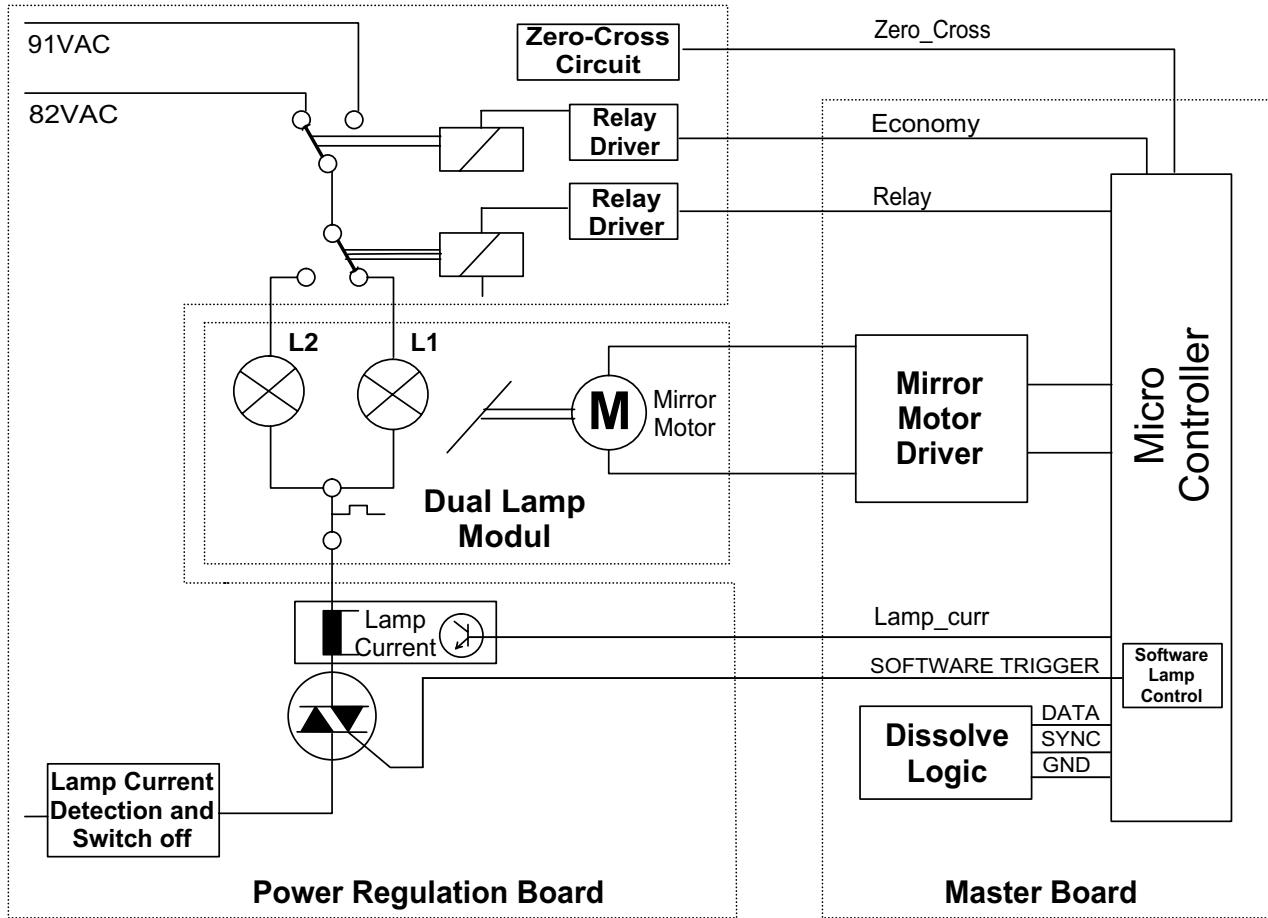

figure 3-10

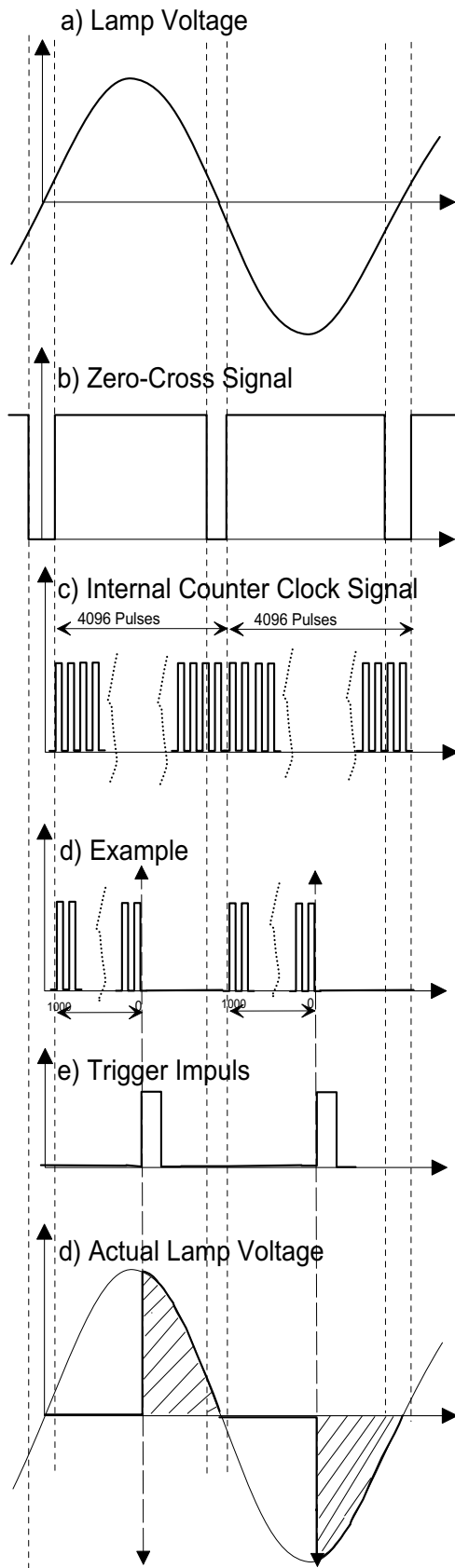

figure 3-11

The zero-cross circuit creates an impulse whenever the LAMP voltage crosses the zero line (LAMP voltage close to zero). See figure b.

Therefore, every 10ms for 50Hz or 8,3ms for 60Hz a signal change occurs. This signal is sent to the DISSOLVE LOGIC on the MASTER PCB. The DISSOLVE LOGIC generates a clocksignal with 4096 pulses for the length of half a sine wave. This clock signal is triggered by the zero-cross signal. See figure c.

Through the DATA SIGNAL, the MICROCONTROLLER delivers a value between 3 and 3700 to the DISSOLVE LOGIC. Values of 0 to 4096 are possible, but these values would cause false phase cut positions because the zero-cross signal does not detect zero on the sine wave.

At the next zero-cross of the LAMP voltage, the DISSOLVE LOGIC reads the value in the MICROCONTROLLER. This value can range from 0 to 1000, and is counted by internally generated clock signal. The clock signal sends the TRIAC TRIGGER signal to the TRIAC CONTROL on the POWER CONTROL PCB.

The TRIAC is energized and the LAMP is energized for the rest of that half sine wave.

If the MICROCONTROLLER sends a new value, the next half would have a different phase cut position. If the value is not changed, the cut position leaves unchanged.

The LAMP dissolve function operates between zero and high with an accessory in the accessory slot or with RS232. High or low on the LAMP is controlled by the BRIGHTNESS SWITCH.

The dissolve range of zero to full brightness is divided into 1000 steps. These steps can be used to create a linear LAMP brightness change.

A lookup table is used in the MICROCONTROLLER software. This table contains the corresponding phase cut value for each one of the 1000 steps for a linear brightness setting.

Focus

There are different possibilities to get a crisp and clear focused image on the screen.

1. Use the FOCUS KNOB. In this case the LENS will be moved inside the LENS CARRIER, while the LENS CARRIER still keeps his position.
2. Use the FOCUSING BUTTONS either on the KEYBOARD of the PROJECTOR or on the REMOTE CONTROL. In this case the LENS and the LENS CARRIER are moving together. The focus range is limited, and depend on the ECCENTRIC of the FOCUS MOTOR (approx. 8mm / 0.3 in.).

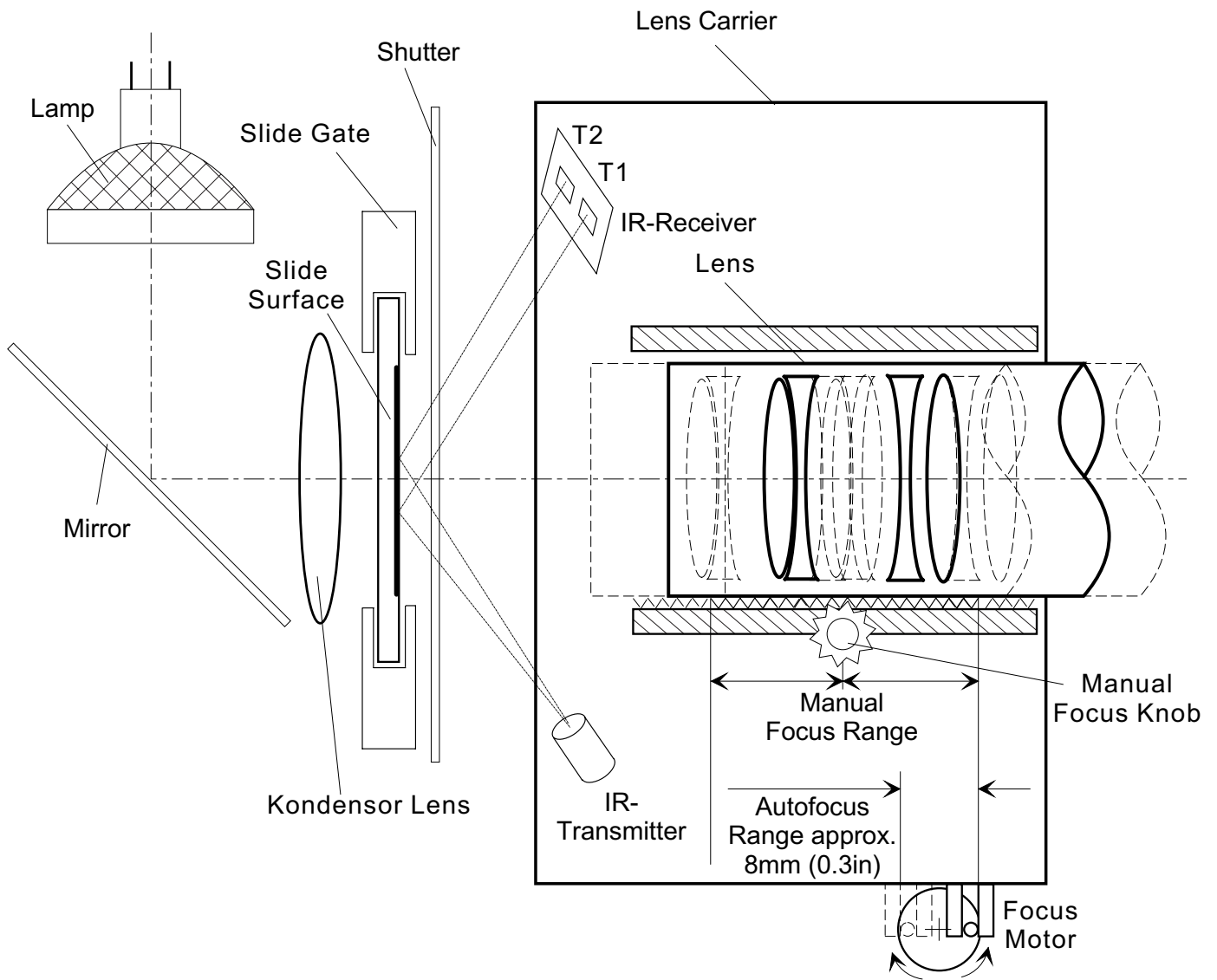

figure 3-12

AUTO FOCUS

The AUTO FOCUS feature is installed in the EKTAPRO Model 5020,9020 and 9020/CINE.

A “low” FOCUS EXT signal from the MICROCONTROLLER enables the AUTO FOCUS PCB while a “high” signal disables the AUTO FOCUS to ensure a sharpness correction for the projected slide. If a manual sharpness correction was necessary the AUTO FOCUS MOTOR moves back to its primary position after the next slide change. The AUTO FOCUS MOTOR is running until both receivers has the same light input. The FOCUS MOTOR stops at the time the light input on both Photo transistors is equal. The direction for the focus movement is defined by either receiver port 1 or port 2.

An electronic circuit will determine the operating voltage for the FOCUS MOTOR (running forwards or backwards) to ensure to have the same speed in both directions. This regulation is necessary because the LENS CARRIER is basic loaded with a spring in one direction.

To ensure that the AUTO FOCUS function works properly it is very important to use the same kind of slide frames. Mixing up glass slides with other slides will bring the projected image out of focus because there is only one reference point for the lens position to get a sharp and clear projected image on the screen.

If glassless slide frames are in use, it could be, that the borders of the projected image are out of focus. It depends on the IR-Beam which is only sensing the center of the slide.

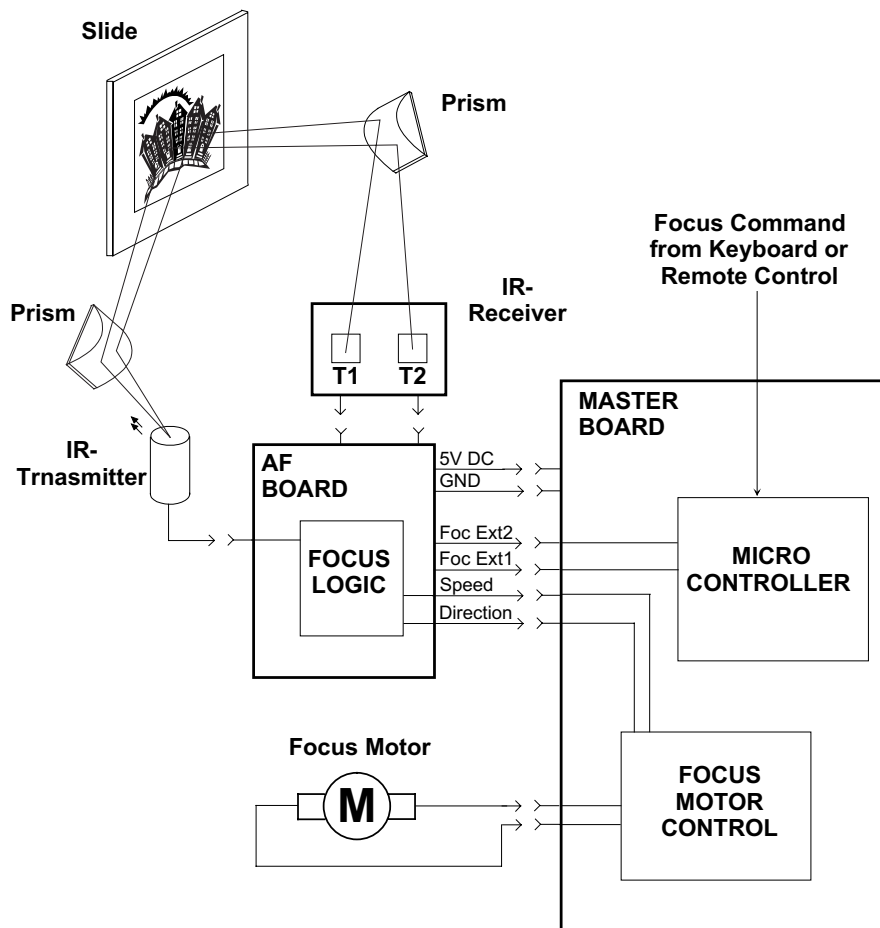

figure 3-13

P-BUS

All the Models are equipped with the P-Bus feature.

The Models 4020 and 5020 has only an Input Bus, Models 7020 and 9020 and 9020/CINE an IN/OUT Bus.

The P-Bus (Presentation Bus) is a serial asynchronous data transmission interface which uses the RS 232 / V.24/ V.28 standard. This type of interface is used with Personal Computers for external communication.

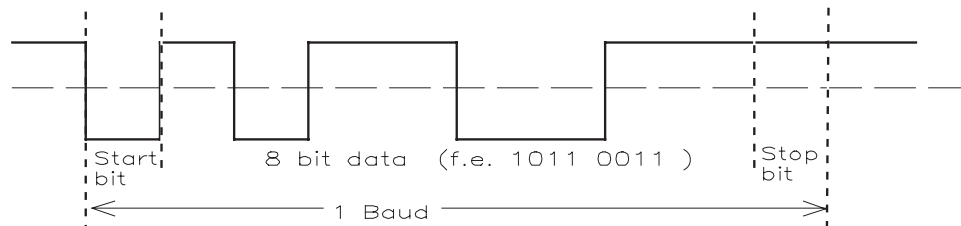

figure 3-14

The purpose of the bus is to enable computer controlled projection with one or more slide projectors. Up to 16 different EKTAPRO 7020 or 9020 and 9020/CINE projectors can be addressed separately if they are connected through a daisy chain configuration. The projector addresses can be selected on the PROJECTORS ADDRESS SELECTOR SWITCH which is located above the P-Bus connectors.

The P-Bus interface configuration is initially set at:

- 1 Start bit
- 8 Data bit
- 1 Stop bit
- 9600 Baud rate
- No Parity

The signal levels must be equal to the RS232 specifications.

The signal lines are only "Transmit Data" and "Receive Data". Bi-directional lines are not used.

The projector can be controlled by other control signals beside the P-Bus Interface. Details can be found in a special marketing publication.

The P-Bus is also used as Service Interface for the Diagnostic Software.

Command Structure

The Command Structure is binary coded with three consecutive 8-bit bytes. Synchronization is achieved by a break in the transmission of more than three byte times. The first five bit of each command specifies the address of the selected projector.

The 16 hardware addresses are 0-F (hex).

The address 1F (hex) is a global address that all connected projectors will accept. Several projectors can be combined in a group by assigning them a special group address of 10 - 19 hex with a software command. Note, global or group addresses are separate from the position that is selected on the address switch.

Three 8-bit bytes:

AAAAA MM 1	CCCC XXXD	XXXXXXXXD
1. Byte	2. Byte	3. Byte

AAAAA	address of projector
MM	selects command mode
CCCC	commands depending on selected mode
XXXX XXXX XXX	commands or information depending on selected mode

An example of command modes is:

- | | | |
|-----------------------|----|---|
| - parameter mode | 00 | |
| - set/reset mode | 01 | |
| - direct mode | 10 | |
| - status request mode | 11 | In this mode, the projector returns (10 bit) data.
This mode can be used for diagnostics purposes. |

Details can be obtained from special marketing literature.

Accessory slot

This slot was designed for EKTAPRO Models 7020, 9020 and 9020/CINE to receive certain professional dissolve units. The 12/7 PIN ADAPTER is a PCB with:

- an “Intern/Extern” switch for a check. Intern means “Lamp on” and Extern means “Projector is controlled by the dissolve unit”.
- connectors to connect the ADAPTER to the projector, and an ADAPTER CABLE for different dissolve units. The ADAPTER CABLE has a 25 PIN SUB-D connector to connect the PCB ADAPTER and a combination socket for 12 and 7 PINS.

Accessories that allow the EKTAPRO projectors to communicate with older dissolve equipment are available for the 12/7 PIN sockets.

The slot contains an Inter IC Communication Interface (I²C). The I²C bus is used in a modified way only for the 7/12 PIN Adapter. Typical I²C functions are not available.

a) Possible Control Functions

- P-Bus function in TTL Level through RS_232_R and RS232_T lines
- LAMP dissolve through SL_DISS line
- I²C Communication through SDA, I²C_INT and SLC lines
- Voltage Supply for accessory slot modules. See 2.4 CONNECTORS.
- Special Control lines SLOT_A, SLOT_B, SLOT_C
All lines are connected to ground means 12/7 PIN adapter present, PROJECTOR LAMP off, waiting for dissolve pulses on SL_DISS line
- all high, no ACCESSORY installed

Remote Control

Type Mini DIN

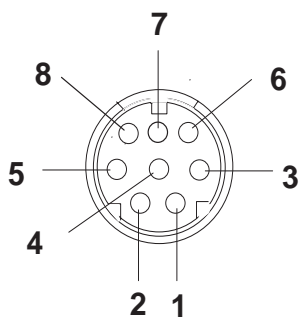

(viewed from front)

figure 3-16

Pin No.	Signal
1	12 VDC
2	Gnd
3	Signal 1 (LSB)
4	Signal 2
5	Signal 3
6	Signal 4
7	Signal 5 (MSB)
8	Interrupt

12 VDC = average value between 7.2 VDC and 14.5 VDC

Because of the microprocessor, the REMOTE CONTROL also works with digital signals on the TTL level. RANDOM ACCESS is also available through a REMOTE CONTROL receptacle.

The data is sent parallel as a 5 bit code from the CABLE REMOTE or the IR RECEIVER to the projector (Keyboard PCB) with an interrupt signal.

The example shows the binary code 10000. The code 10000 is for FORWARD.

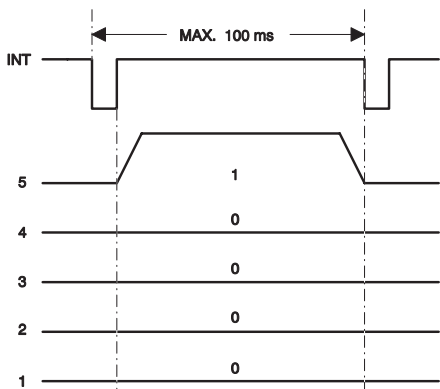

figure 3-15

When a button on the REMOTE CONTROL is pressed, the INT signal is low with a maximum value of 1 μ s. Then it becomes high again. After that the data transmission begins.

While the focus and tray motion signal consist of only one 5 bit data record. The slide position values are always sent as three successive 5 bit data.

For example:

Slide No. 3 = decimal 20 20 23 , binary 10100 10100 10111
 Slide No. 140 = decimal 21 24 20 , binary 10101 11000 10100

List of Remote Control Commands:

Key/Function	Command decimal	Command binary
		5 4 3 2 1
Slide forward	16	1 0 0 0 0
Slide backwards	8	0 1 0 0 0
Focus forward	4	0 0 1 0 0
Focus backwards	2	0 0 0 1 0
Standby	1	0 0 0 0 1
Key 1	21	1 0 1 0 1
Key 2	22	1 0 1 1 0
Key 3	23	1 0 1 1 1
Key 4	24	1 1 0 0 0
Key 5	25	1 1 0 0 1
Key 6	26	1 1 0 1 0
Key 7	27	1 1 0 1 1
Key 8	28	1 1 1 0 0
Key 9	29	1 1 1 0 1
Key 0	20	1 0 1 0 0
Clear	Internal	
Enter	3 words internal	

blank page

4. DISASSEMBLY/ASSEMBLY

UPPER HOUSING

1. Remove the LAMP MODULE.
2. Remove the KNOB.
3. Remove the 4 SCREWS.
4. Remove the UPPER HOUSING.

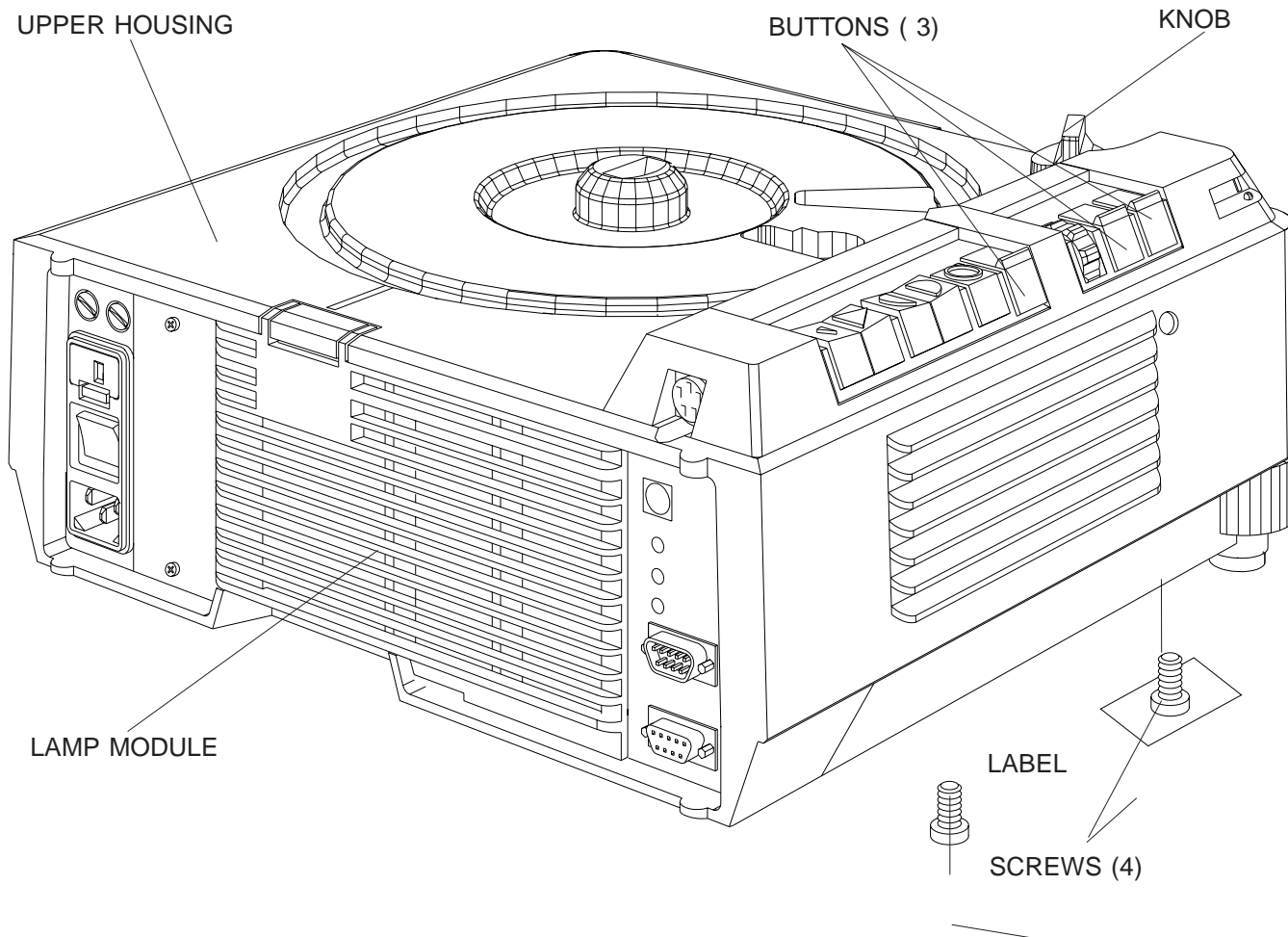

figure 4-1

BUTTONS and COVER PLATES

1. Remove the UPPER HOUSING. See page 4-1.
2. Remove the 3 BUTTONS.
3. Remove the small COVER PLATE.
4. Loosen the HOLDING CLIP and remove the large COVER PLATE.
5. If needed, change the 5 BUTTONS.

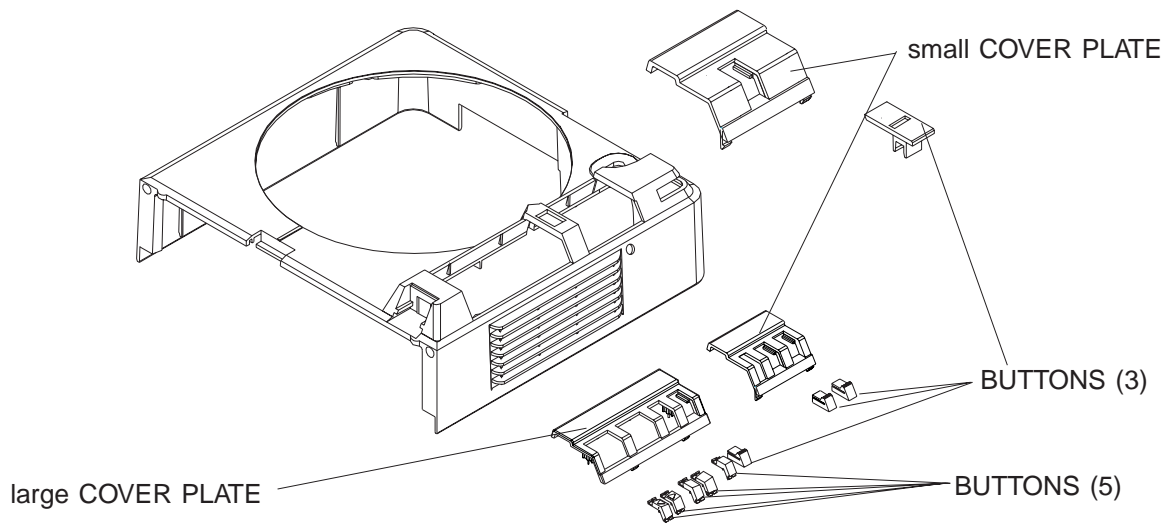

figure 4-3

6. If necessary, replace the WINDOW and/or MODEL LABEL.

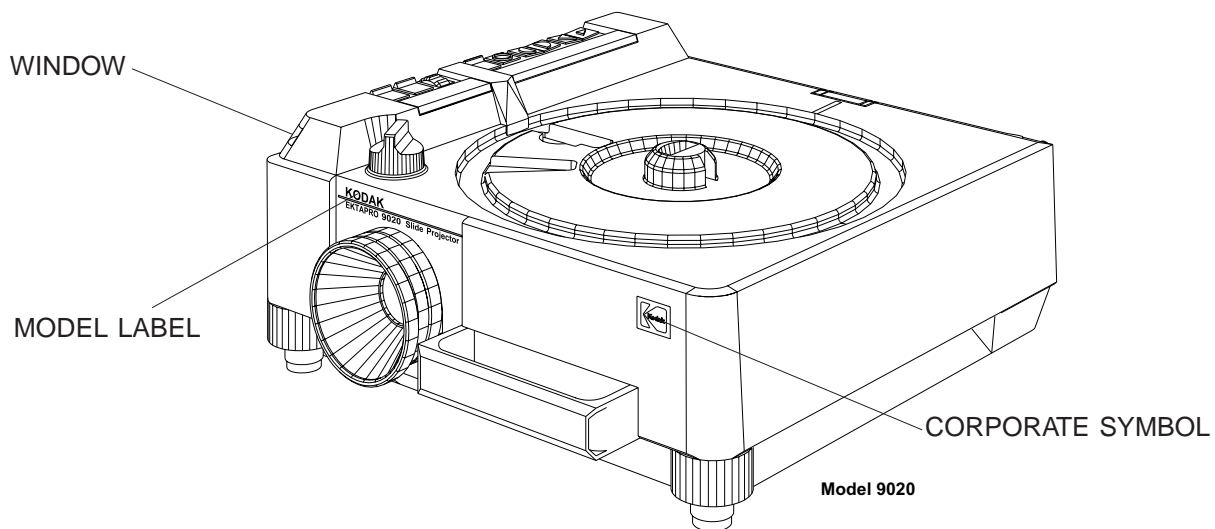

figure 4-2

Assembly

NOTE

Please note the positions of the 3 BUTTONS and the SWITCH on the KEYBOARD PCB.

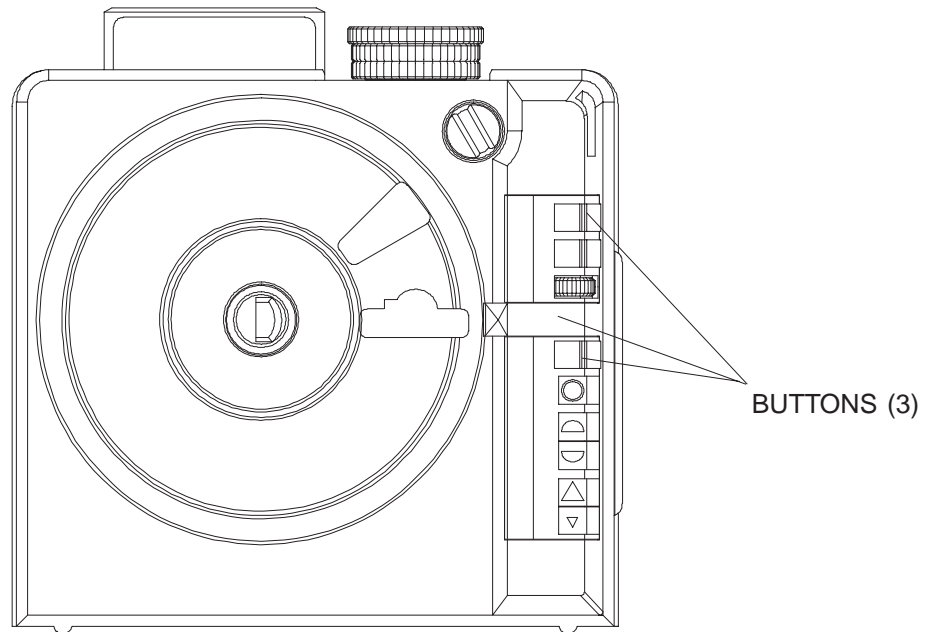
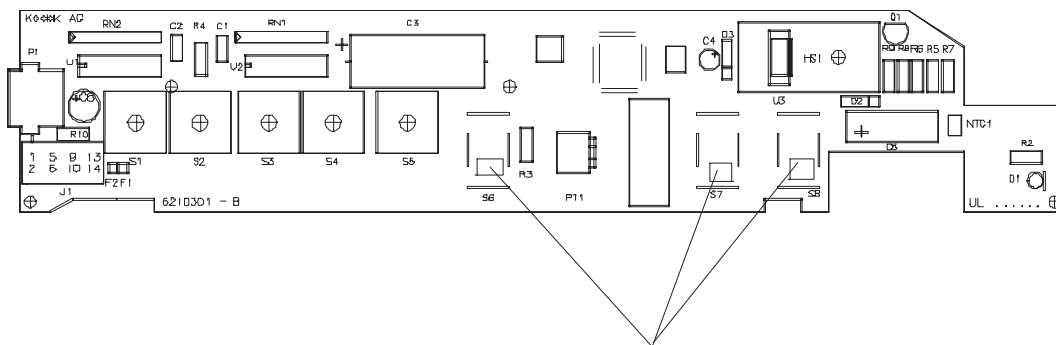

figure 4-4



SWITCH POSITION on the KEYBOARD PCB

figure 4-5

CENTER HOUSING

1. Remove the UPPER HOUSING. See page 4-1.
2. Remove the FOCUS INDICATOR.
3. Release the HOLDING CLIP at the KEYBOARD and remove the PCB.
4. Release the HOLDING CLIP at the TRAY MOTION PCB and remove the PCB.

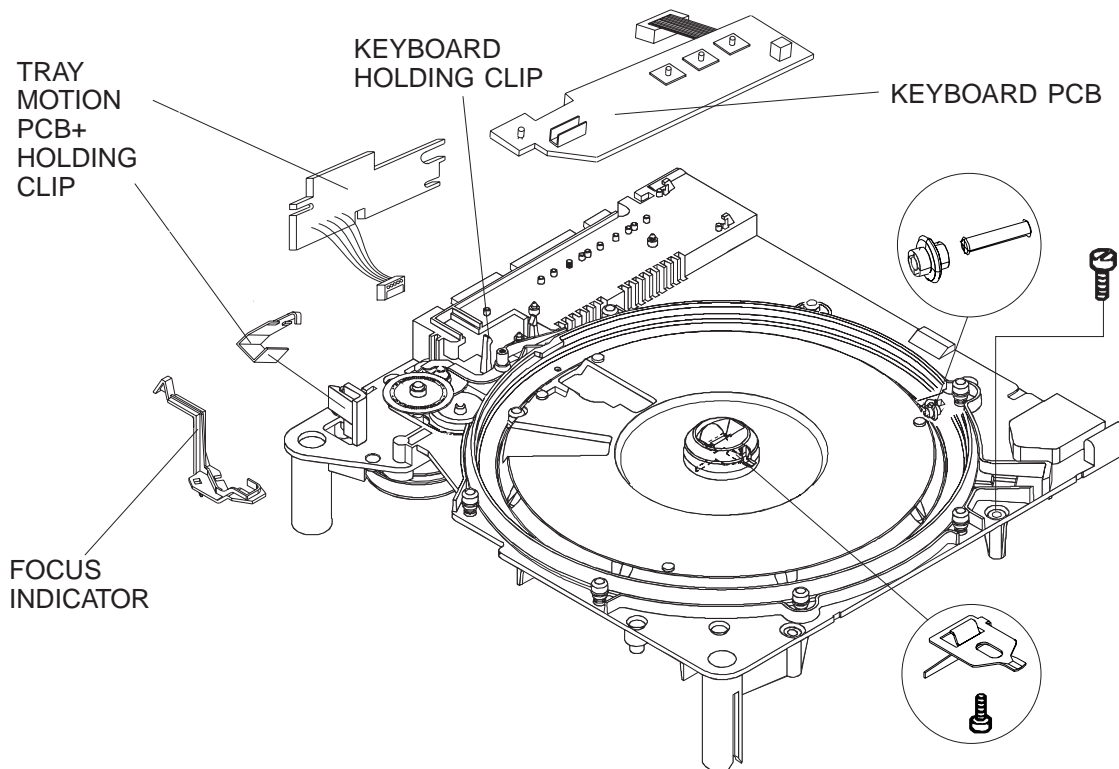

figure 4-6

5. Remove the SPRING and the ZERO LEVER. See figure 4-7.
6. Remove the 8 RETAINERS and 8 ROLLERS. See figure 4-7.
7. Remove the DRIVE RING. See figure 4-7.
8. Remove the 3 SHAFT ROLLERS and the 3 BEARING ROLLERS. See figure 4-7.

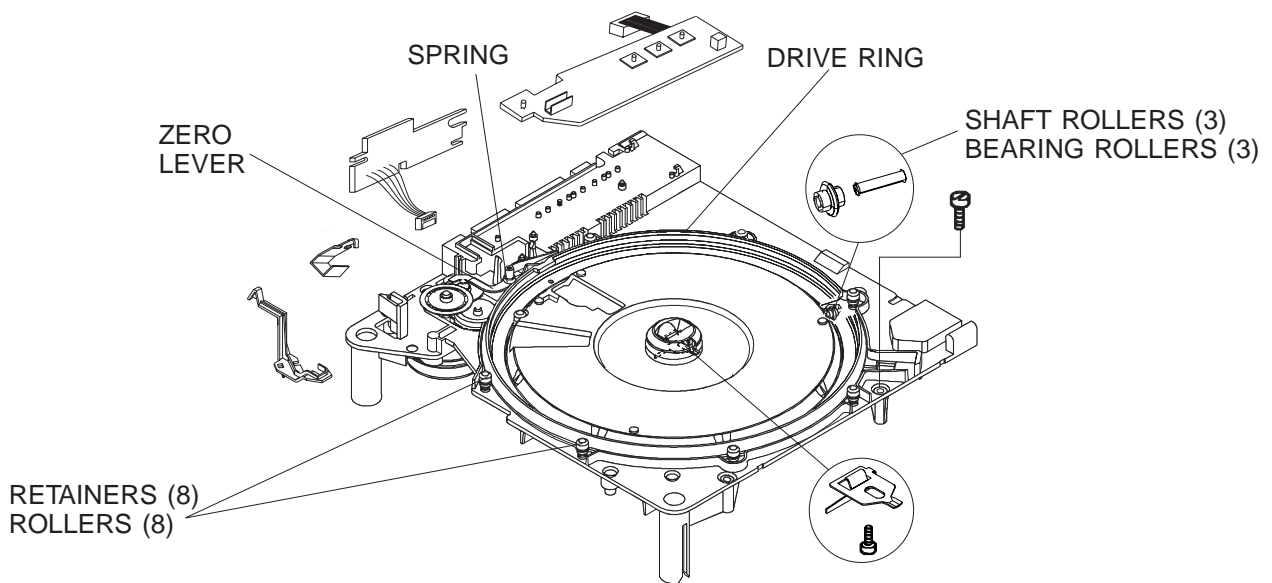

figure 4-7

9. Remove the CODER DISK and 2 GEAR WHEELS.

10. Remove the 4 SCREWS.

11. Remove the CENTER HOUSING.

12. Remove the 2 SCREWS and the MOTOR.

13. Remove the SCREW and the LATCH

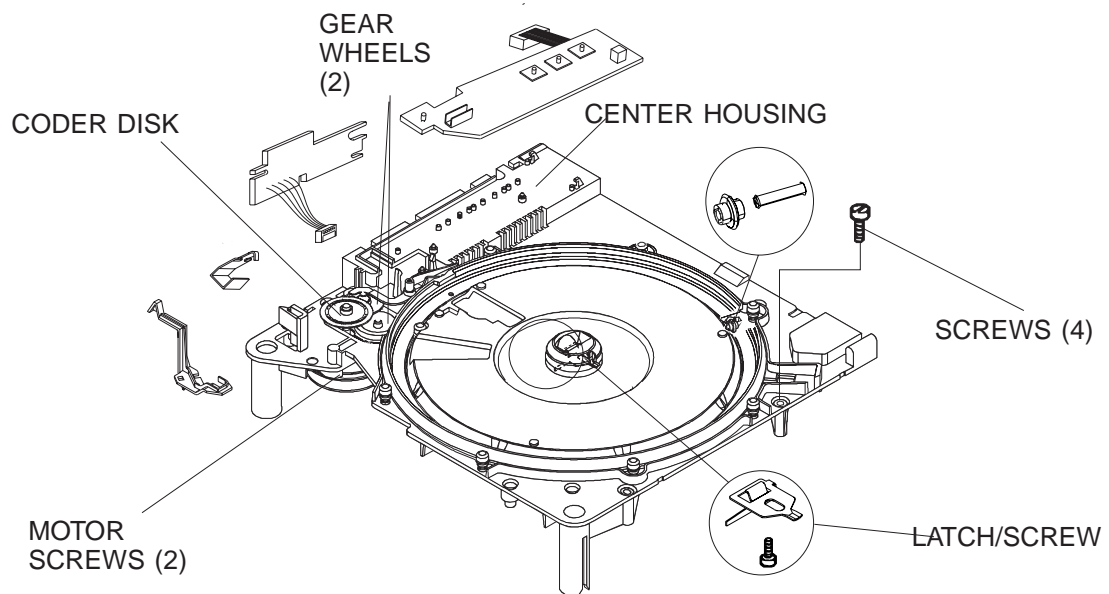

figure 4-8

14. During disassembly and assembly of the CENTER HOUSING, place the TRAY RELEASE LEVER into the position as shown below.

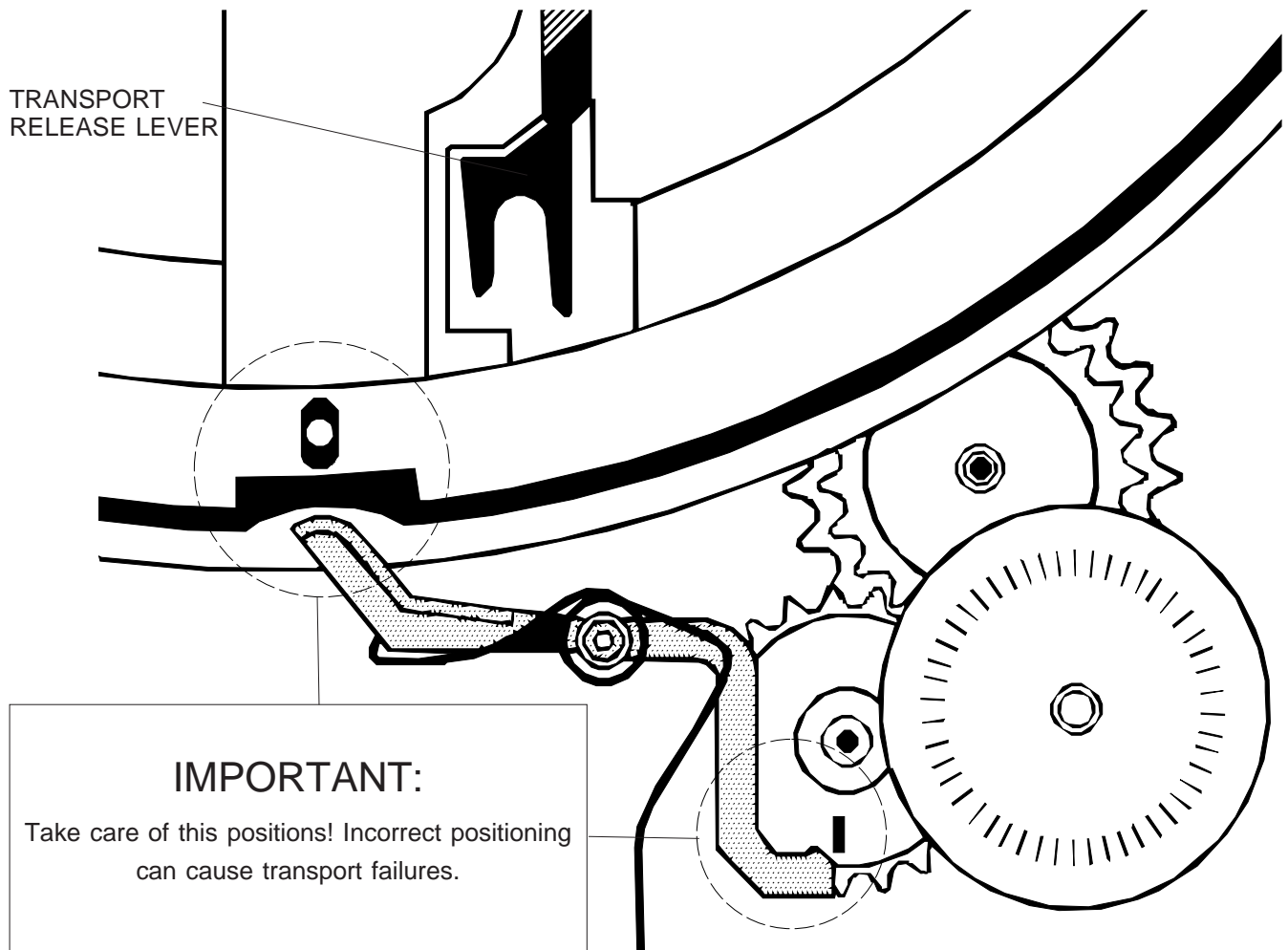

figure 4-9

15. At the accessory slot, insert the ADAPTER into the GUIDE of the CENTER HOUSING.

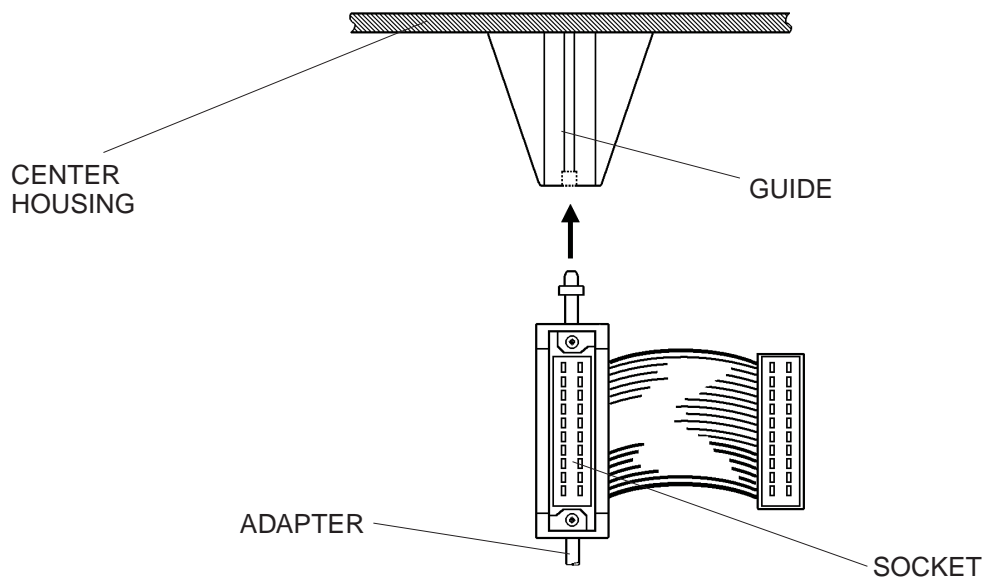

figure 4-10

16. Check that the POWER SUPPLY PCB is positioned in the GUIDE of the CENTER HOUSING.

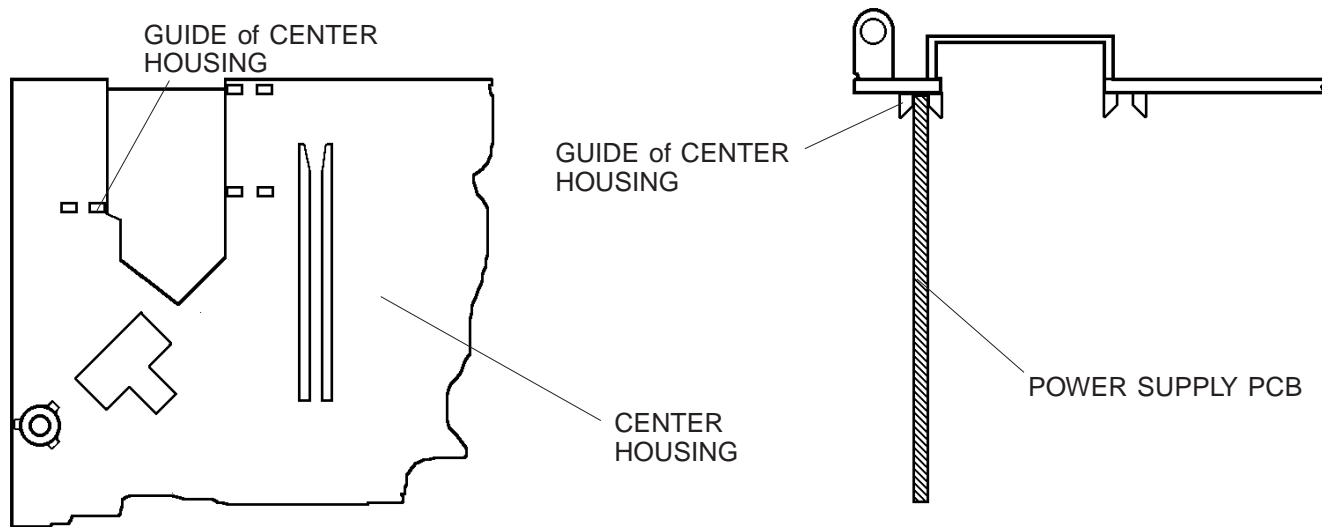

figure 4-11

FAN, KEYBOARD PCB and TRAY MOTION PCB

1. Remove the UPPER HOUSING. See page 4-1.
2. Remove the CENTER HOUSING. See page 4-4.
3. Disconnect the FAN MOTORS.
4. Remove the FAN.
5. Disconnect the KEYBOARD PCB.
6. Disconnect the TRAY MOTION PCB.

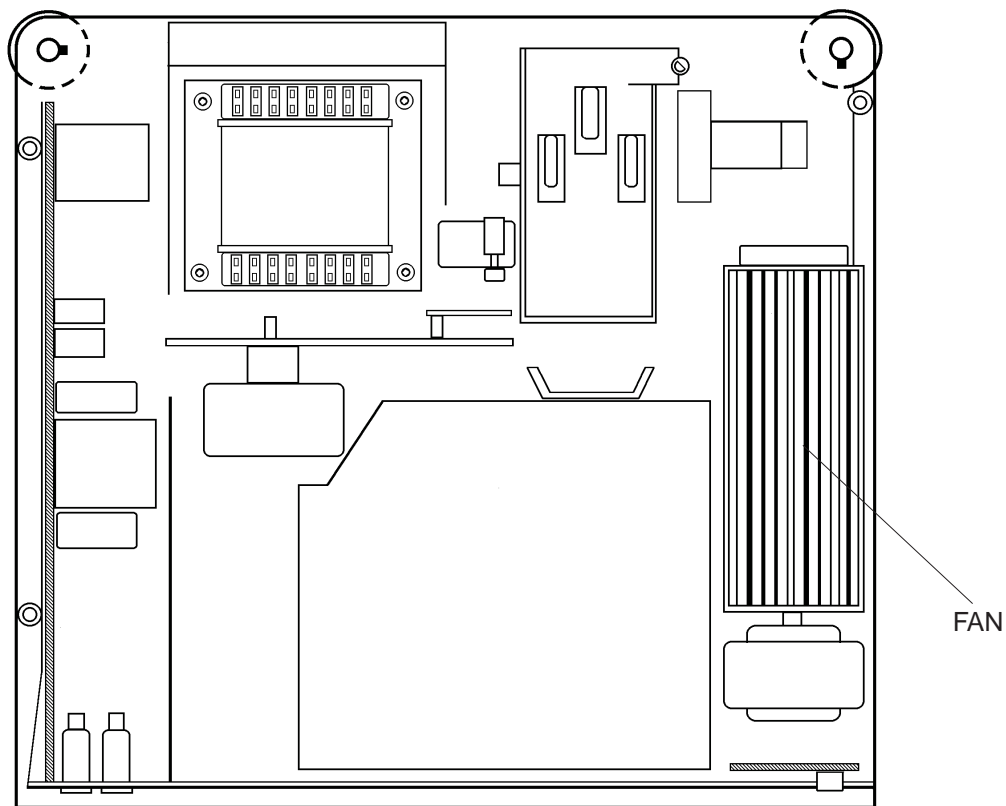

figure 4-12

NOTE:

Do not clean the FAN with compressed air because the rotary wings would be damaged!

NOTE

When placing the FAN in the LOWER HOUSING, insert the FAN as shown in figure 4-13.

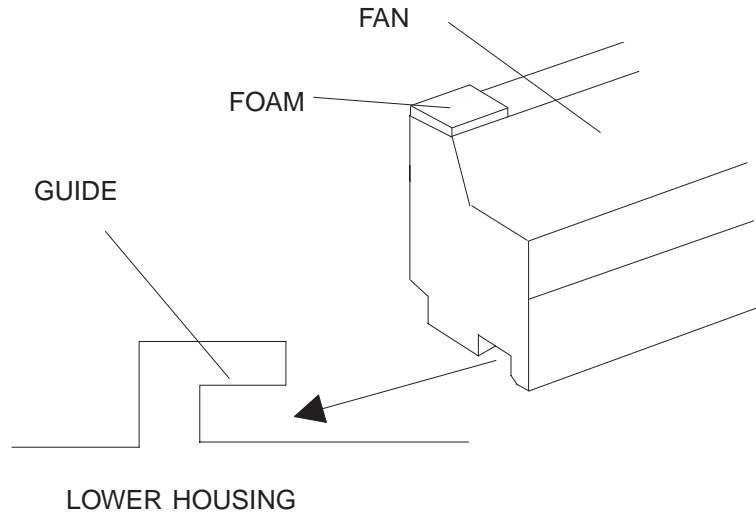

figure 4-13

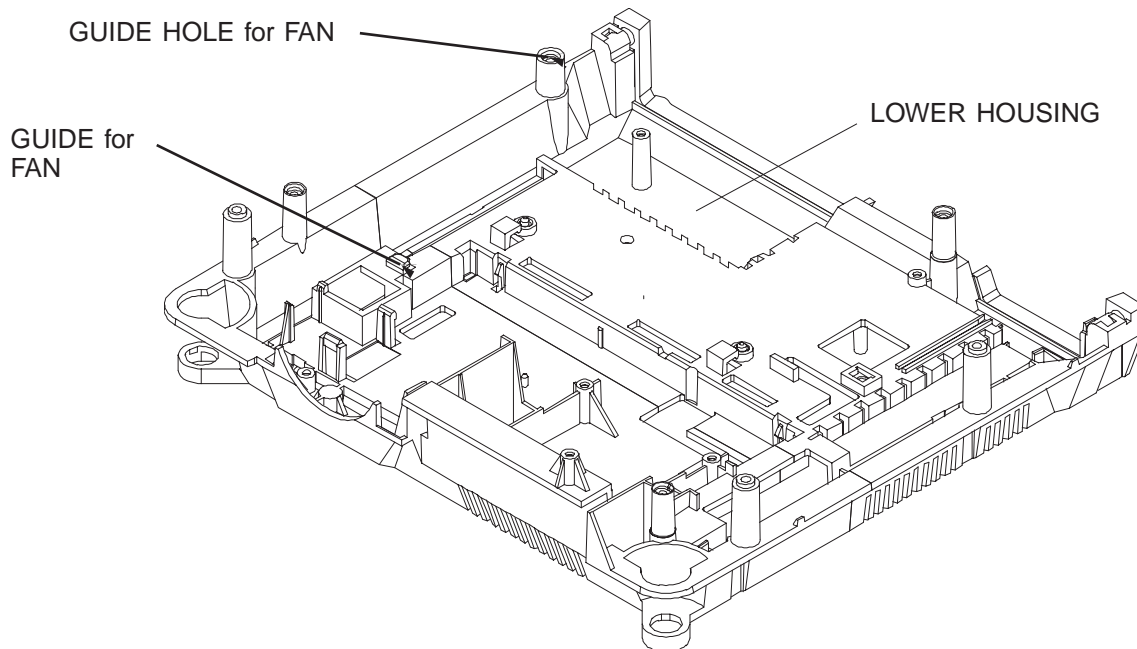

figure 4-14

BACK PANEL PCB

1. Remove the UPPER HOUSING. See page 4-1.
2. Remove the CENTER HOUSING. See page 4-4.
3. Remove the FAN. See page 4-9.
4. Remove the BACK PANEL PCB.

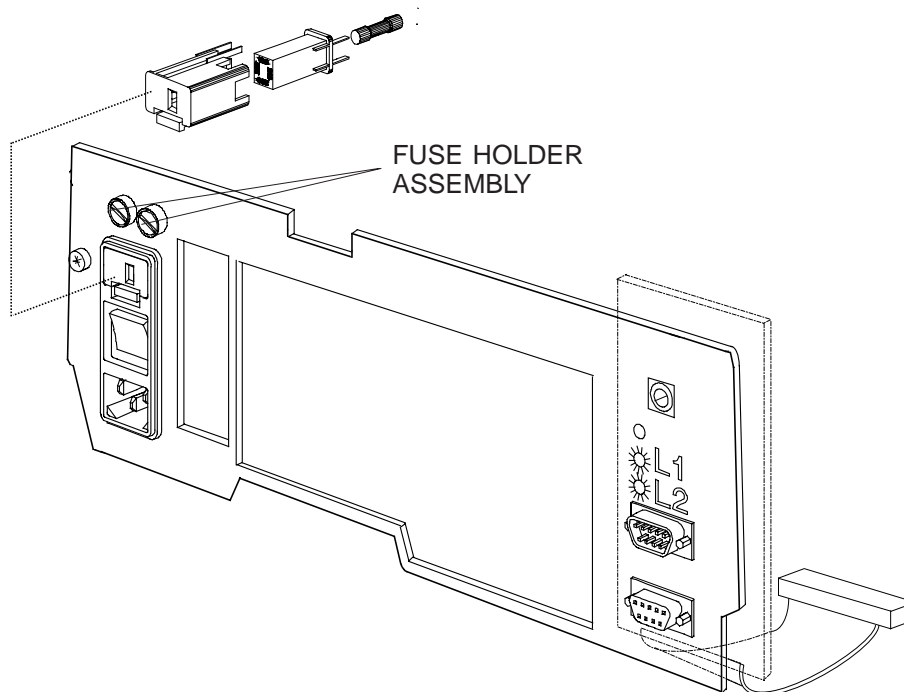

figure 4-15

TRANSFORMER, POWER SUPPLY PCB and BACK PLATE ASSEMBLY

NOTE

It is easier to remove the complete TRANSFORMER, POWER SUPPLY PCB and BACK PANEL ASSEMBLY at the same time, to avoid needless removals.

1. Remove the UPPER HOUSING. See page 4-1.
2. Remove the CENTER HOUSING. See page 4-4.
3. Remove the 4 SCREWS from the TRANSFORMER
4. Remove the CONNECTOR P3 from the POWER SUPPLY PCB.
5. Remove the NEUTRAL WIRE at the MECHANISM FRAME and the LAMP HOUSING ASSEMBLY.
6. Disconnect POWER SUPPLY PCB from the MASTER BOARD PCB. Remove the TRANSFORMER and the BACK PLATE ASSEMBLY.
7. If needed, install new assemblies.

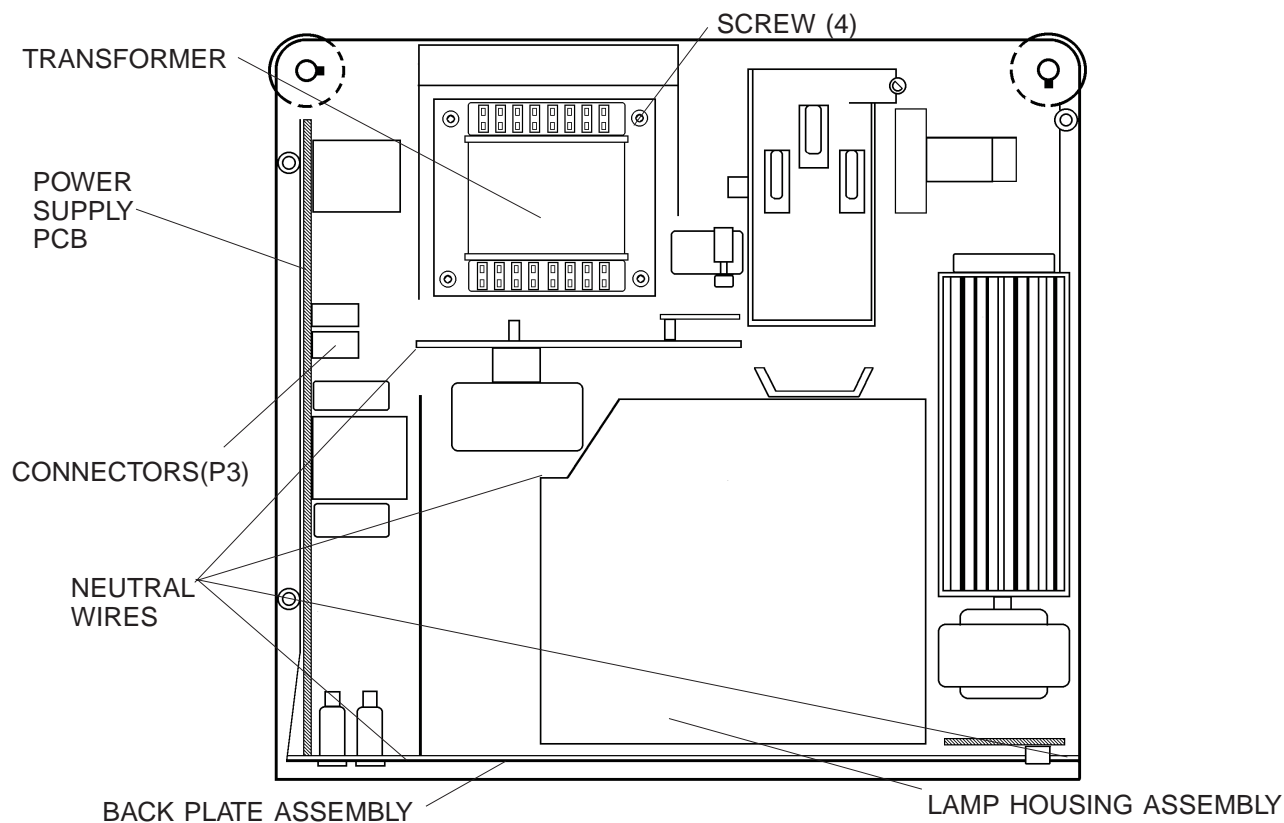

figure 4-16

MECHANISM FRAME and LENS MOUNT

1. Remove the UPPER HOUSING. See page 4-1.
2. Remove the CENTER HOUSING. See page 4-4.
3. Remove the 4 SCREWS and the TRANSFORMER. See page 4-11.
4. Remove the SCREW and disconnect the NEUTRAL WIRE.
5. For Model 5020, 9020 and 9020/CINE remove the SCREW, the AF PCB and the 2 CONNECTORS from the AF PCB.
6. Lift the MECHANISM FRAME and LENS MOUNT and remove the 3 CONNECTORS J 3, J 10, J 12. See page 4-19.

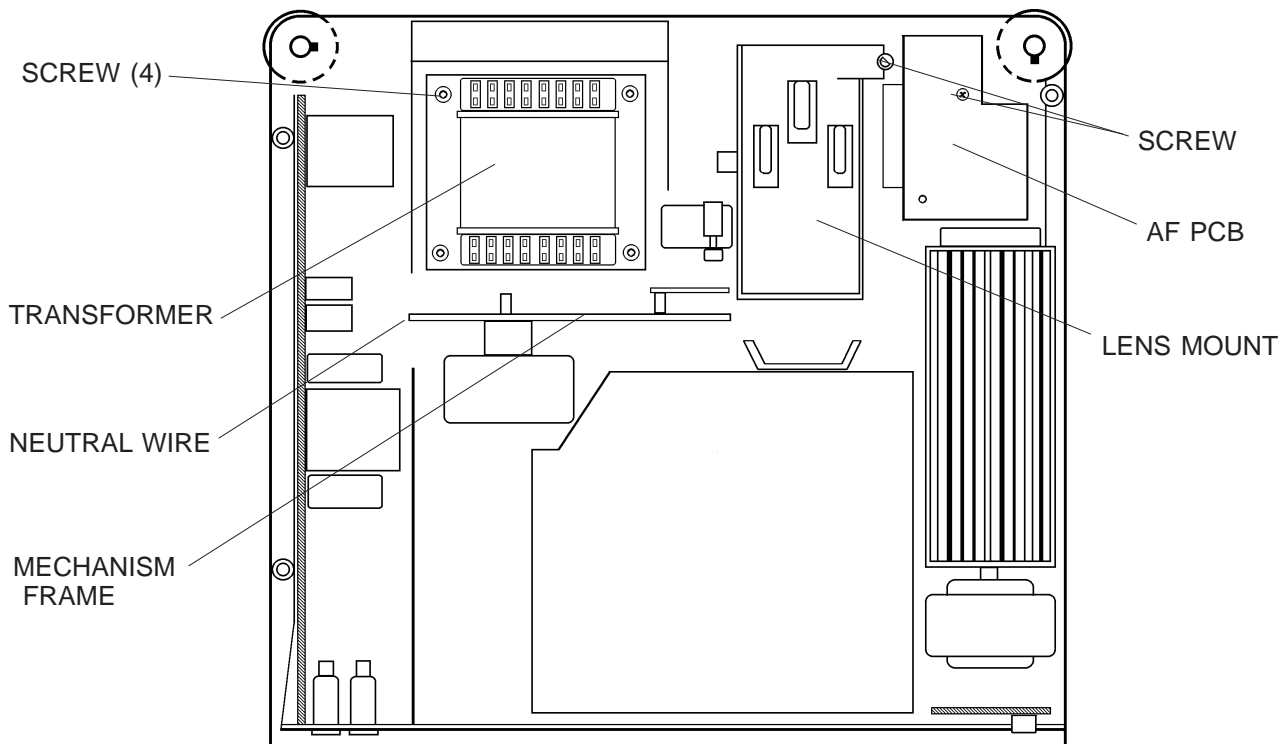

figure 4-17

LENS MOUNT

1. Remove the UPPER HOUSING. See page 4-1.
2. Remove the CENTER HOUSING. See page 4-4.
3. Remove the 4 SCREWS and the TRANSFORMER. See page 4-11.
4. Remove the MECHANISM FRAME and LENS MOUNT. See page 4-12.
5. Remove the SPRING.
6. Remove the LENS MOUNT from the MECHANISM FRAME.

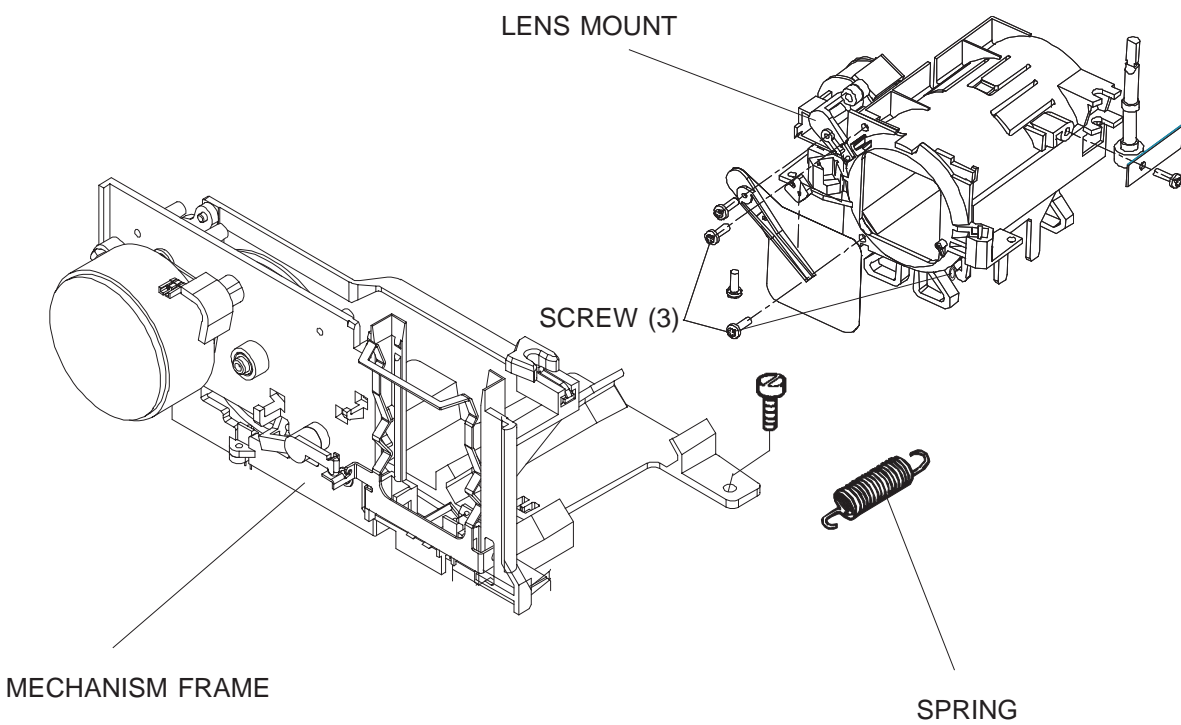

figure 4-18

7. Remove the SCREW, PLATE and the SHAFT.
8. Remove the SCREW, SHUTTER and the SHOCK ABSORBER.
9. Remove the SCREW and the MAGNET.
10. Remove the 3 SCREWS, the AUTO FOCUS RETAINER and the SPRING.

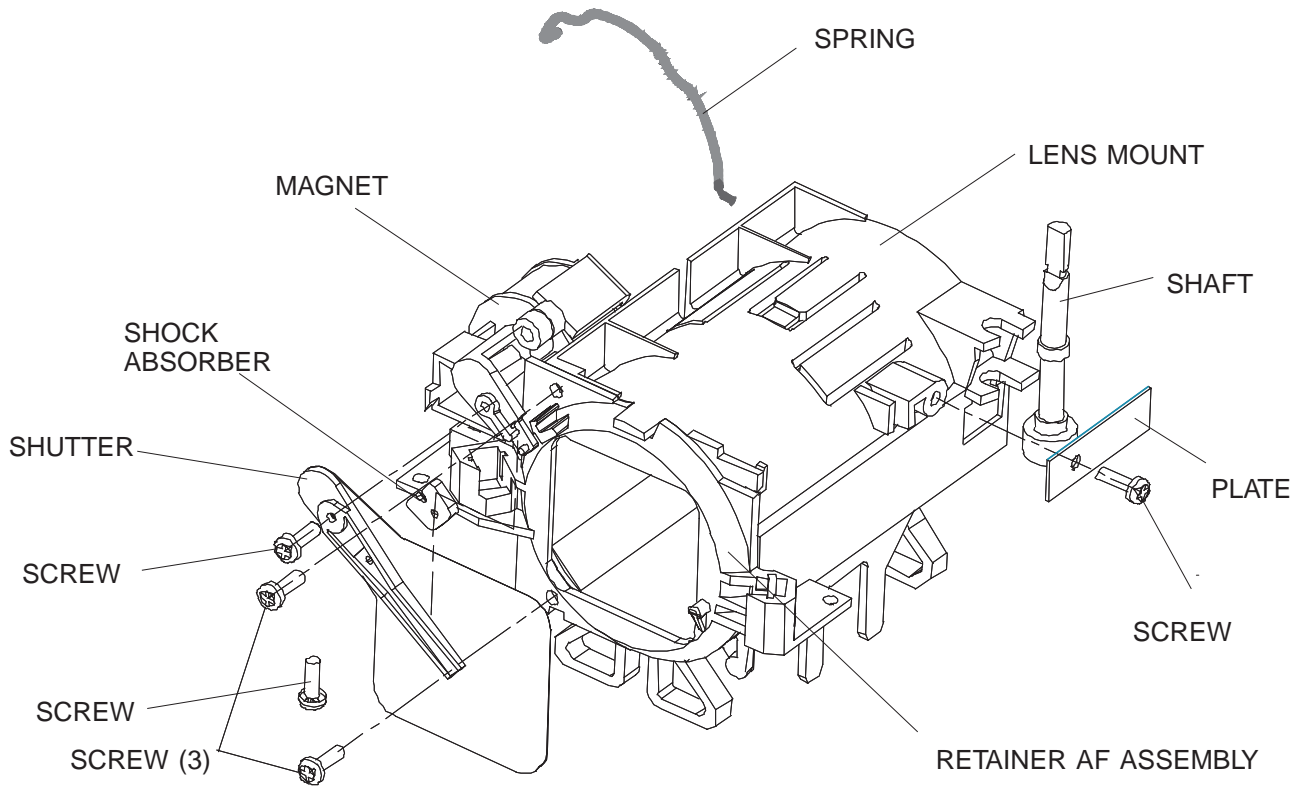

figure 4-19

If the SHUTTER has to be replaced and the COVER MECHANISM FRAME is provided with the small recess, the SHUTTER has to be bent first. Otherwise it might touch the COVER MECHANISM FRAME.

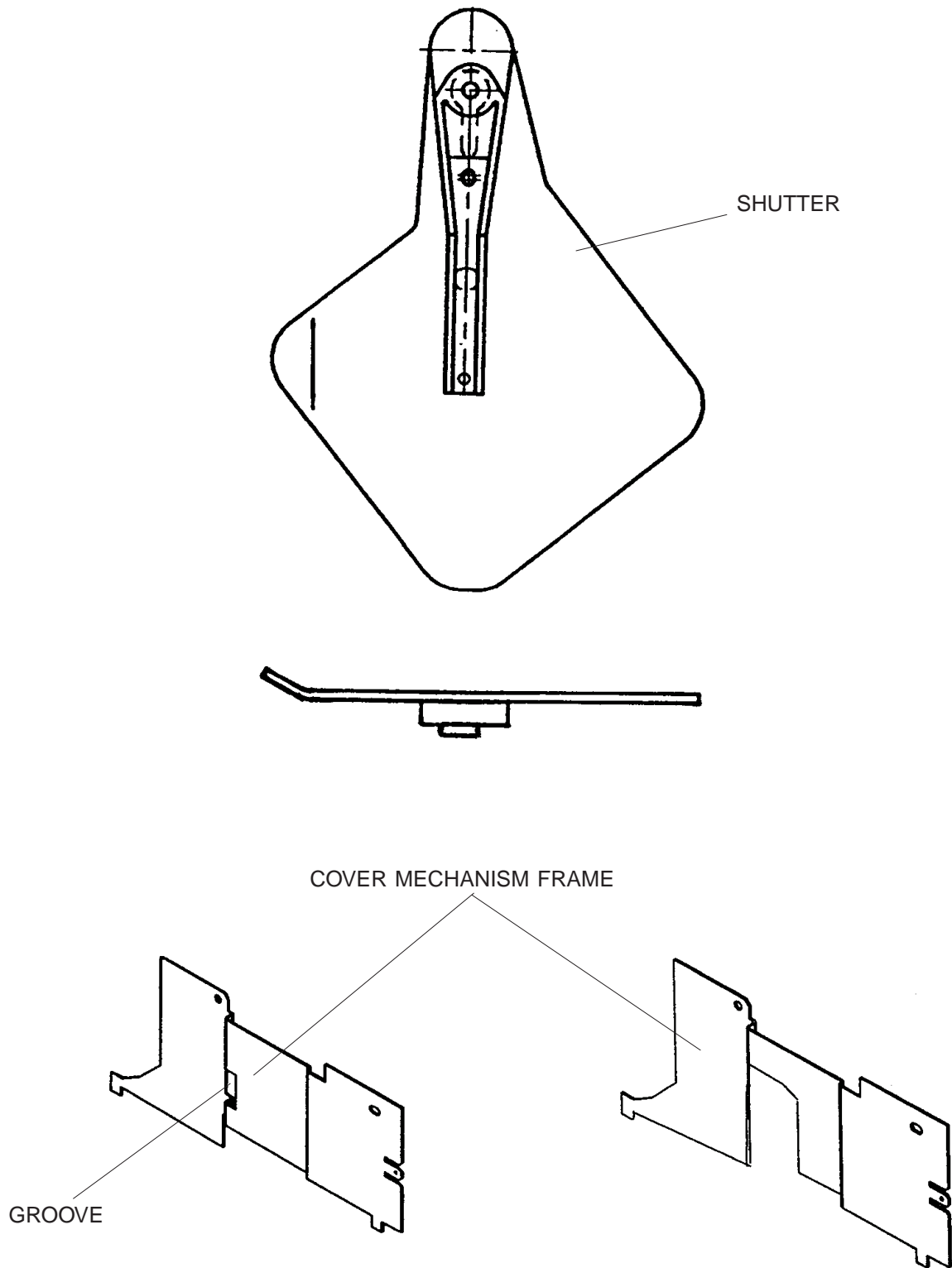

figure 4-20

RETAINER AF ASSEMBLY

Model 5020, 9020 and 9020/CINE

1. Remove the UPPER HOUSING. See page 4-1.
2. Remove the CENTER HOUSING. See page 4-4.
3. Remove the 4 SCREWS and the TRANSFORMER. See page 4-11.
4. Remove the MECHANISM FRAME and LENS MOUNT. See page 4-12.
5. Remove the SPRING and the LENS MOUNT from the MECHANISM FRAME. See page 4-13.
6. Remove the SCREW, SHUTTER and the SHOCK ABSORBER. See page 4-14.
7. Rotate the LEVER for the SHUTTER out at the MAGNET.
8. Remove the 3 SCREWS, the RETAINER AF ASSEMBLY, and the SPRING. See page 4-14.
9. Remove the 2 PRISM COVER and the 2 PRISMS.

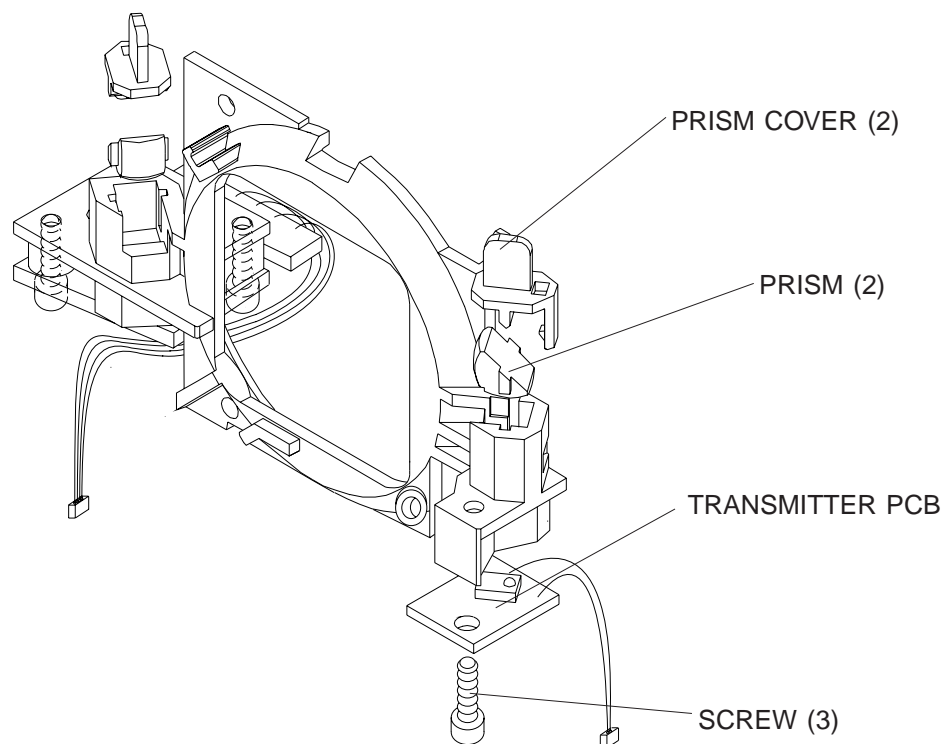

figure 4-21

10. Remove the SCREW, the TRANSMITTER PCB, and the TRANSMITTER COVER.

11. Remove the 2 SCREWS and the RECEIVER PCB.

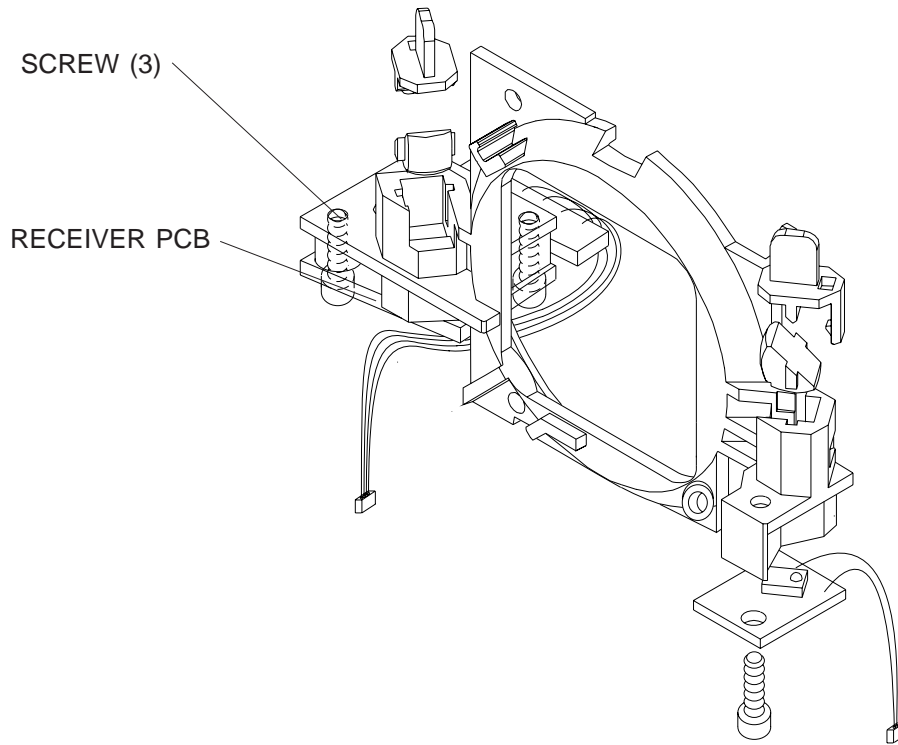

figure 4-22

MECHANISM FRAME

1. Remove the UPPER HOUSING. See page 4-1.
2. Remove the CENTER HOUSING. See page 4-4.
3. Remove the 4 SCREWS and the TRANSFORMER. See page 4-11.
4. Remove the MECHANISM FRAME and LENS MOUNT. See page 4-12.
5. Remove the SPRING and LENS MOUNT. See page 4-13.
6. Remove the 2 SCREWS, 2 WASHERS and the COVER MECHANISM FRAME.

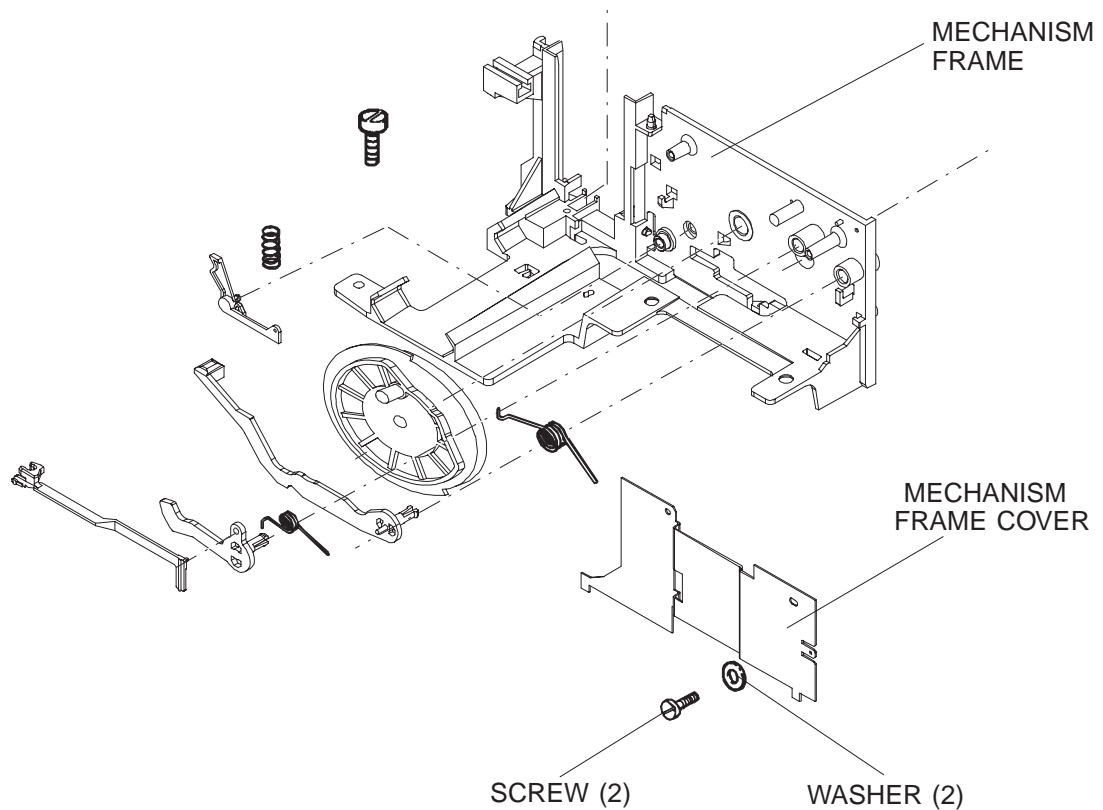

figure 4-23

7. Remove the TRAY RELEASE LEVER. See figure 4-24.
8. Remove the LEVER, SLIDE LIFTER and the 2 SPRINGS.
9. Remove the SPRING, SLIDE REGULATION LEVER and the CAM.

NOTE

After the assembly of the parts, align the CAM so that the SLIDE LIFTER is in the lowest position.

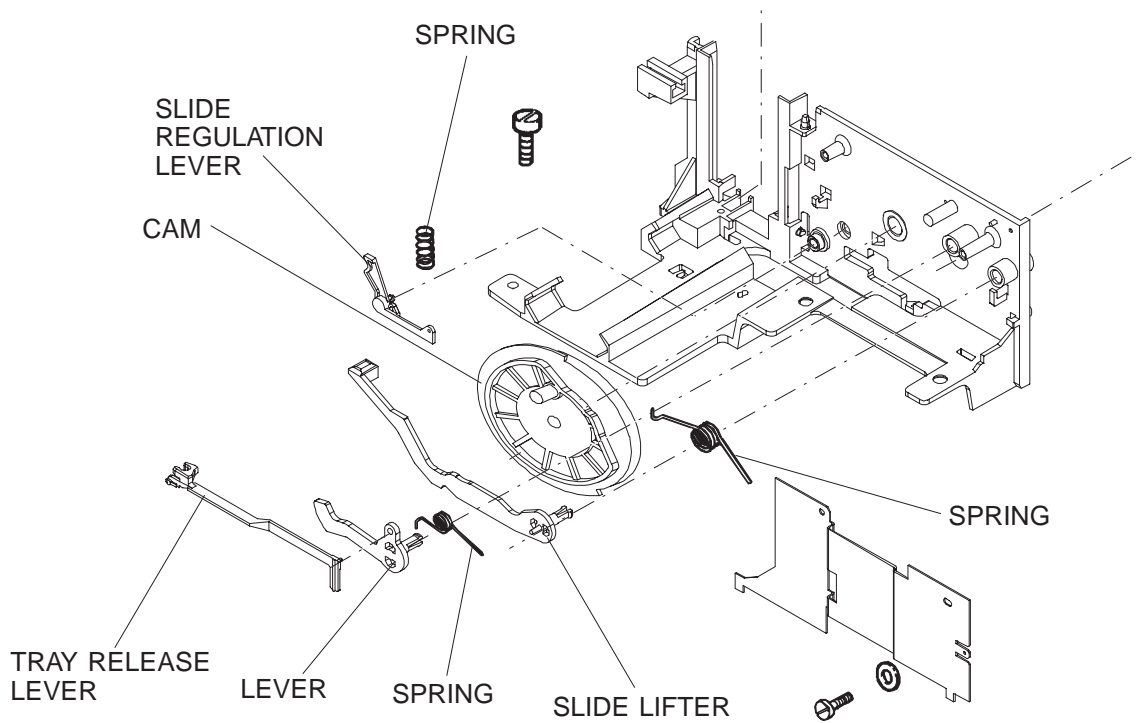

figure 4-24

10. Remove the LEVER and the SPRING.

11. Remove the SPRING and the PRESSURE PAD.

12 Remove the 2 SCREWS, the CAM and the SHUTTER SENSOR ASSEMBLY.

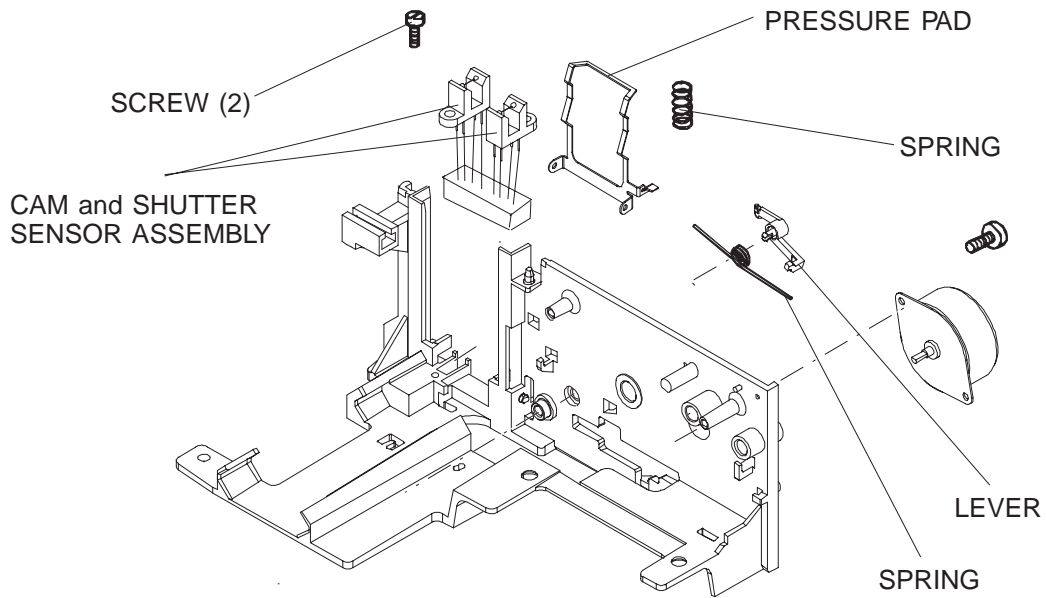

figure 4-25

13. Remove the 2 SCREWS and the MOTOR.

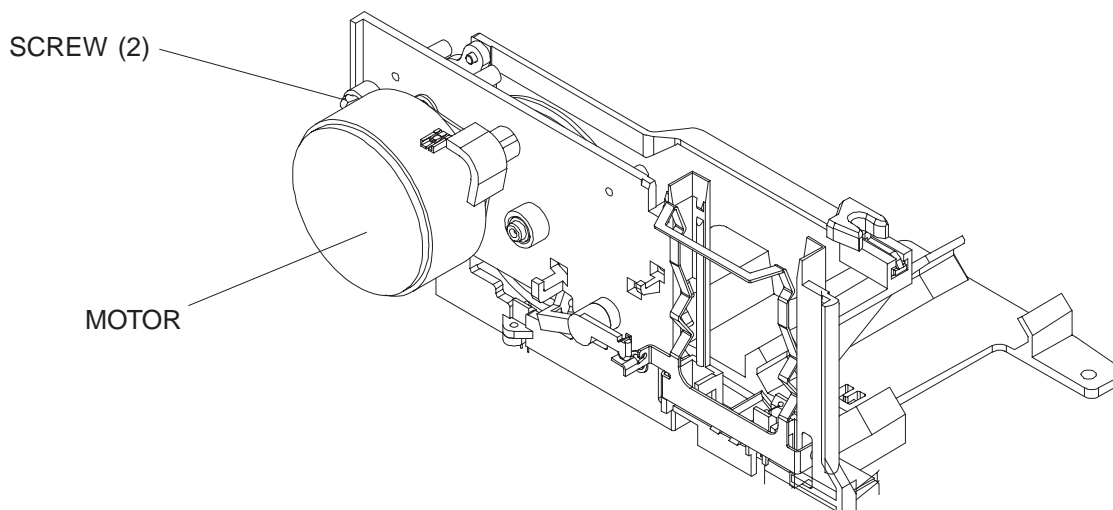

figure 4-26

AUTO FOCUS PCB and FOCUS MOTOR

1. Remove the UPPER HOUSING. See page 4-1.
2. Remove the CENTER HOUSING. See page 4-4.
3. Remove the FAN, KEYBOARD PCB, and TRAY MOTION PCB. See page 4-9.
4. Remove the 4 SCREWS and the TRANSFORMER. See page 4-11.
5. Remove the MECHANISM FRAME and LENS MOUNT. See page 4-12.
6. Remove the SPRING, the FOCUS MOTOR and the RUBBER PAD.

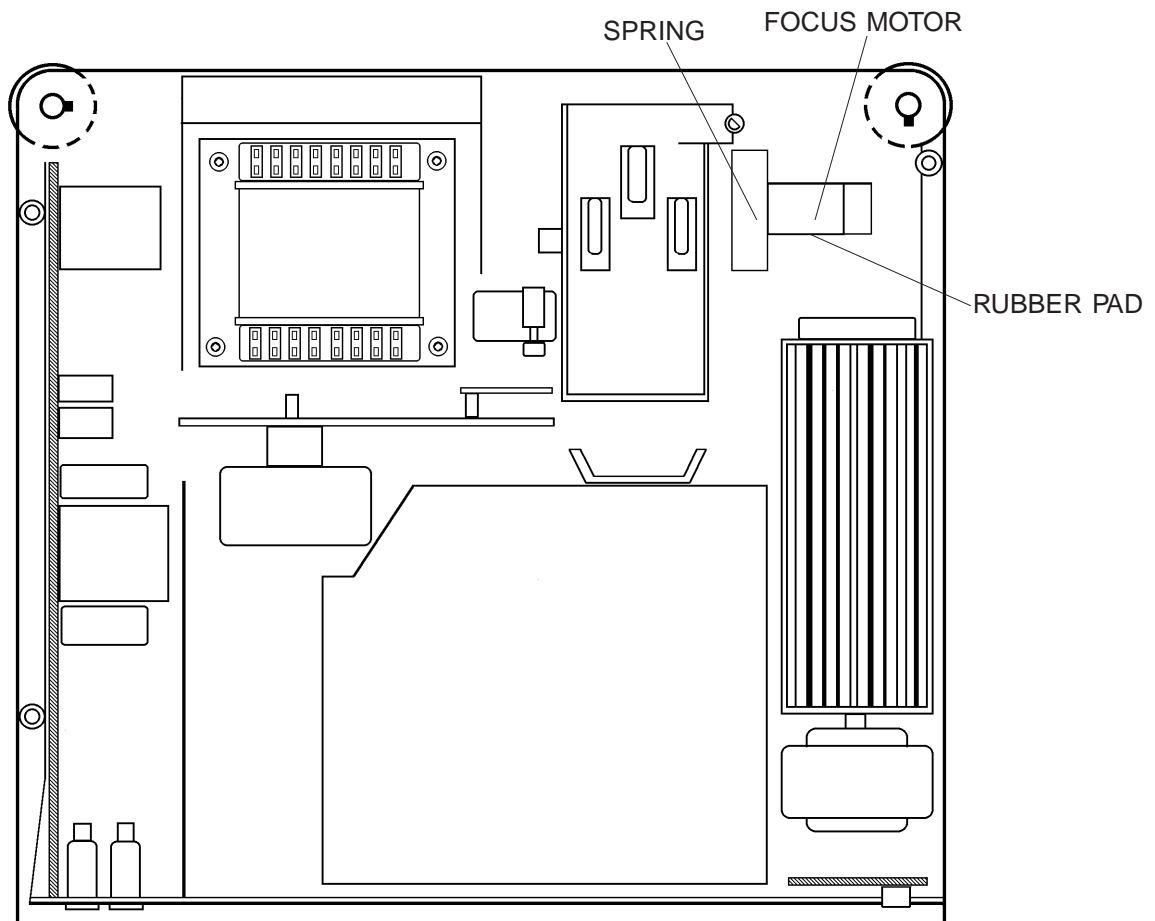

figure 4-27

Master Board PCB

1. Remove the UPPER HOUSING. See page 4-1.
2. Remove the CENTER HOUSING. See page 4-4.
3. Remove the FAN, KEYBOARD PCB and the TRAY MOTION PCB. See page 4-9.
4. Remove TRANSFORMER, POWER SUPPLY PCB and BACK PANEL ASSEMBLY. See page 4-11.
5. Remove the MECHANISM FRAME and LENS MOUNT. See page 4-12.
6. Disconnect all CONNECTORS from the MASTER PCB. See page 4-23:
7. Remove the SCREW and the COVER.
8. Remove the MASTER PCB.

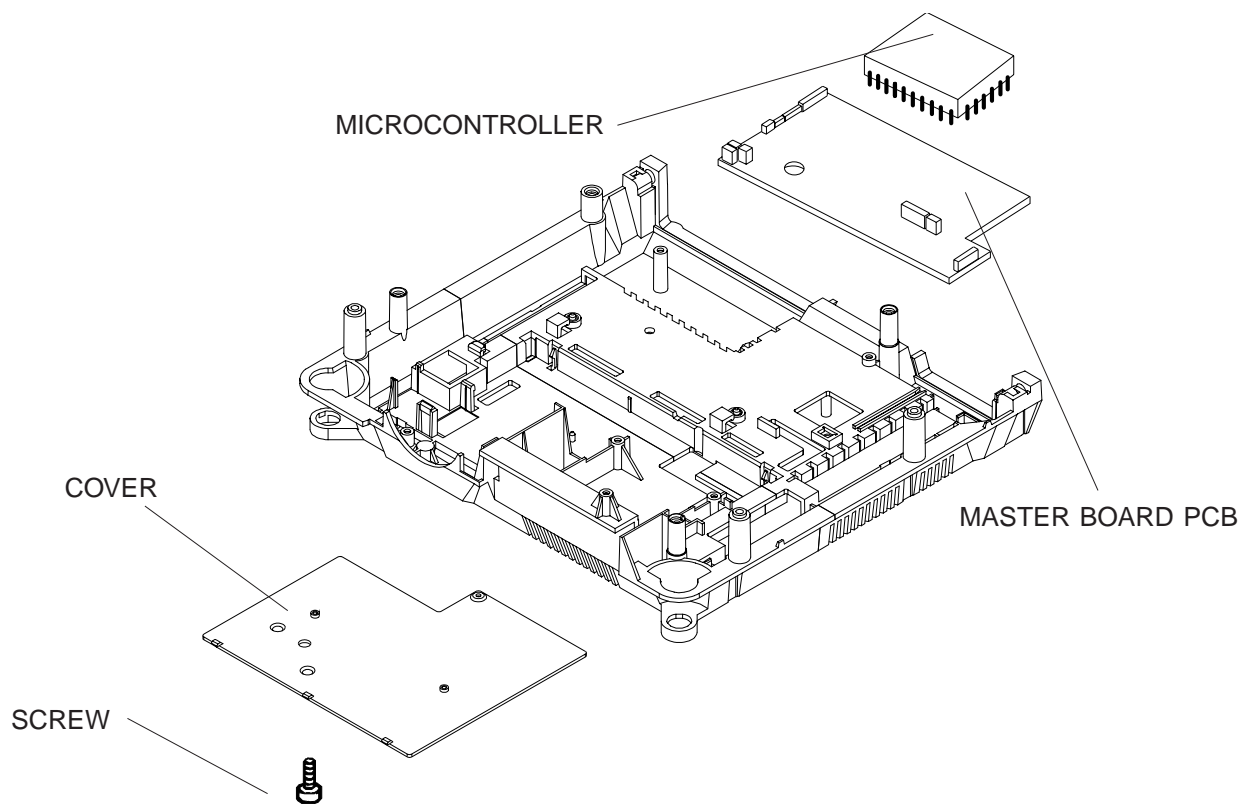
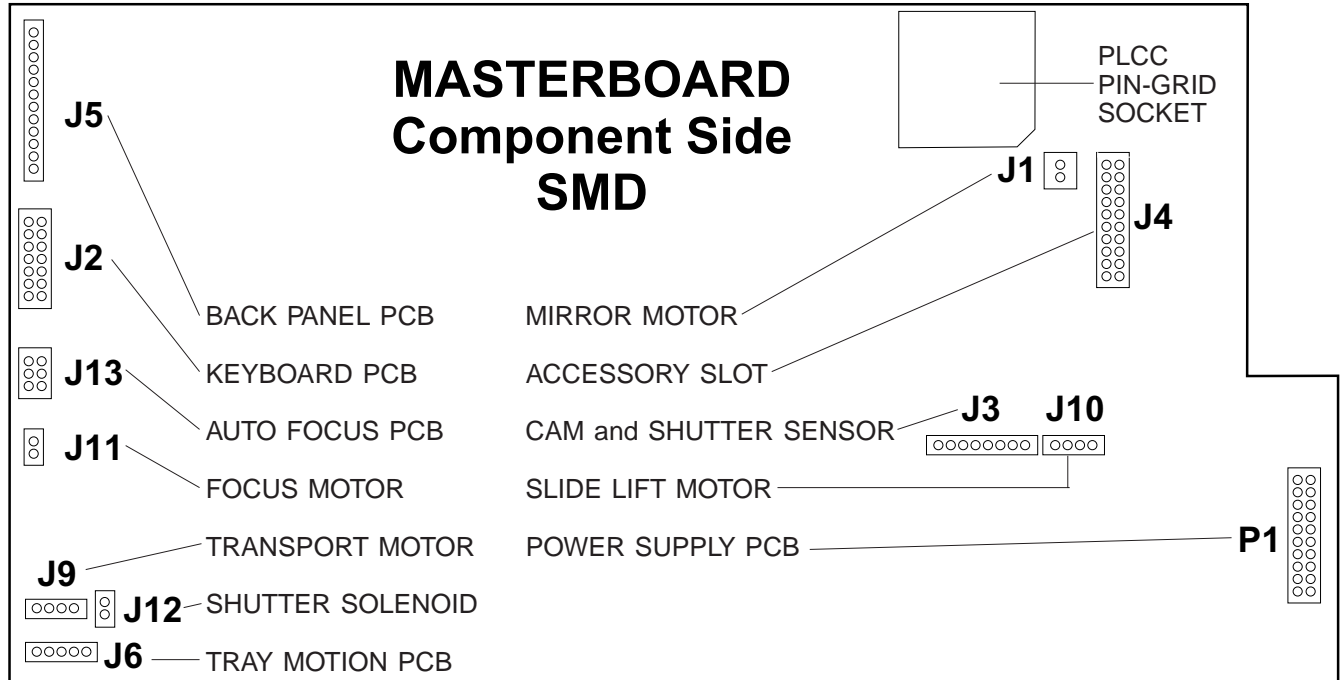

figure 4-28

Master Board PCB Connectors

CAUTION

During the assembly take care that all CONNECTORS are correctly plugged in!



MICROCONTROLLER

1. Remove the UPPER HOUSING. See page 4-1.
2. Remove the CENTER HOUSING. See page 4-4.
3. Remove the SCREW and the COVER.
4. Use a PLCC EXTRACTOR TOOL (TL 4430) to remove the MICROCONTROLLER from the MASTER PCB.
5. When assembling note the beveled edge of the MICROCONTROLLER and the PLCC/PIN-GRID SOCKET. Install these edges together.

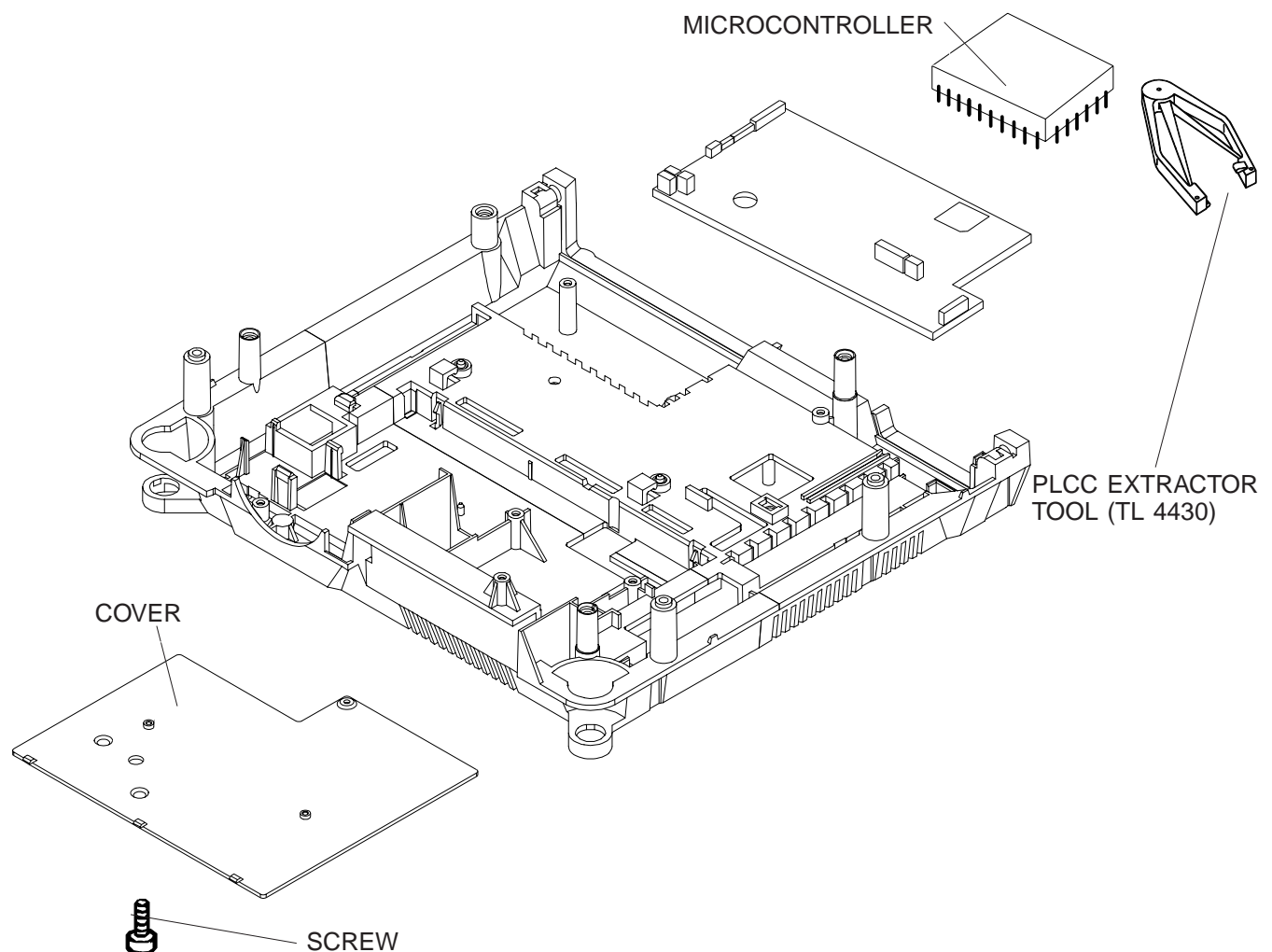

NOTE

The MICROCONTROLLER is installed in a PLCC-Socket.

LOWER HOUSING

1. Remove the UPPER HOUSING. See page 4-1.
2. Remove the CENTER HOUSING. See page 4-4.
3. Remove the FAN, KEYBOARD PCB and TRAY MOTION PCB. See page 4-9
4. Remove the TRANSFORMER, POWER SUPPLY PCB and BACK PANEL ASSEMBLY. See page 4-11.
5. Remove the MECHANISM FRAME and LENS MOUNT. See page 4-13.
6. Disconnect all CONNECTORS from MASTER PCB. See page 4-23:
7. Remove the 2 SCREWS and the LAMP HOUSING ASSEMBLY.
8. Remove the HANDLE.
9. Remove the 2 ELEVATOR RETAINERS, the right and left ELEVATOR KNOB, the right and left ELEVATOR and the 2 RUBBER FEET.

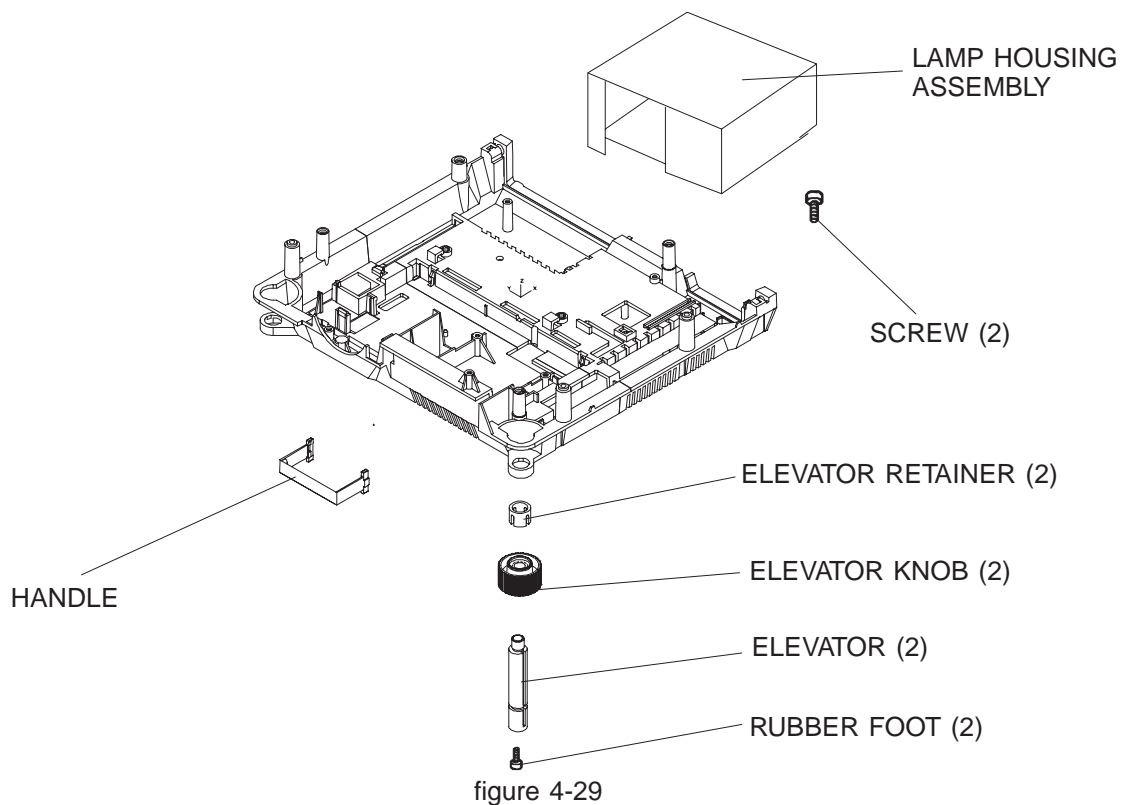

DUAL LAMP MODULE (Extra Bright)

1. Remove the LAMP MODULE from the PROJECTOR.
2. Lift the EJECTOR LEVER . The defective LAMP will eject from the LAMP SOCKET ASSEMBLY.

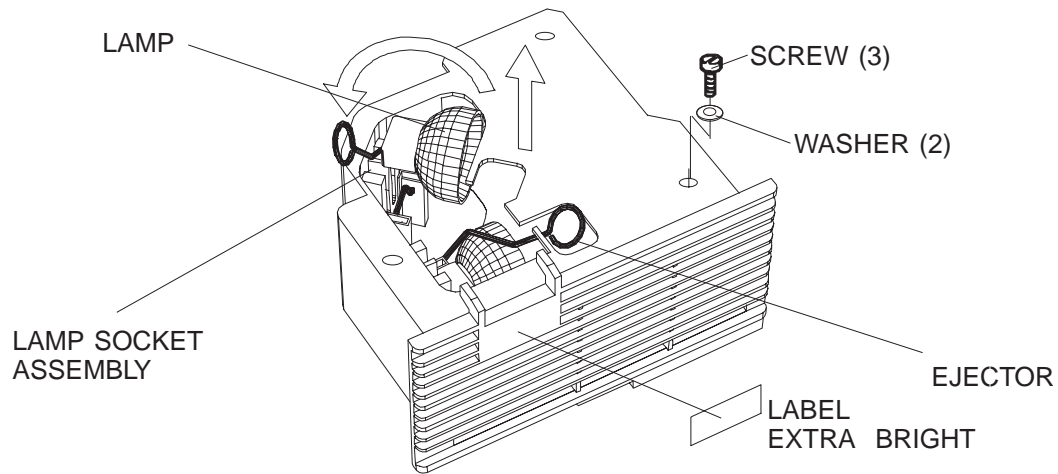

figure 4-30

3. Remove the CLIP and the CONDENSER LENS.

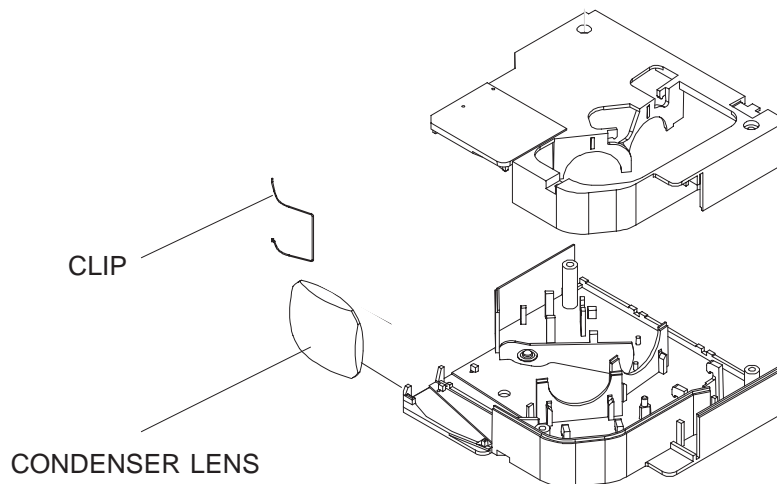

figure 4-31

4. Remove the 3 SCREWS, the 2 WASHERS and the LAMP HOUSING.
5. Remove the GRILL PLATE, the AIR EXHAUST PLATE, the HOOK, the SPRING and the LAMP MODULE LABEL.

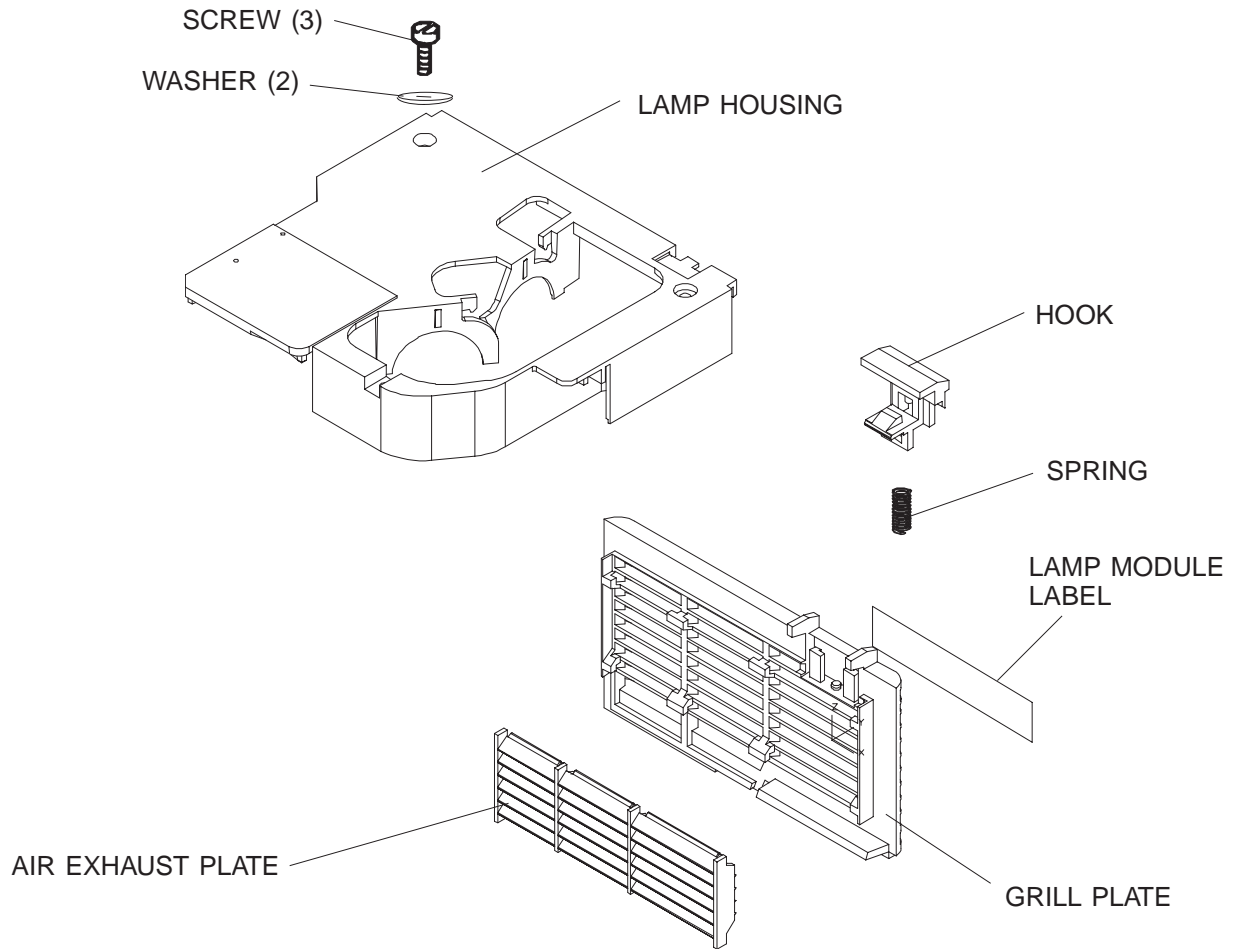

figure 4-32

6. Remove the 2 EJECTORS.
7. Remove the SPRING - Model 4020, 5020, 7020 ,9020 and 9020/CINE.
8. Remove the MIRROR, the SPRING and the MIRROR HOLDER.
9. Remove the MOTOR, the CIRCLIP and the SINGLE or DUAL LAMP SOCKET ASSEMBLY from the PLUG.

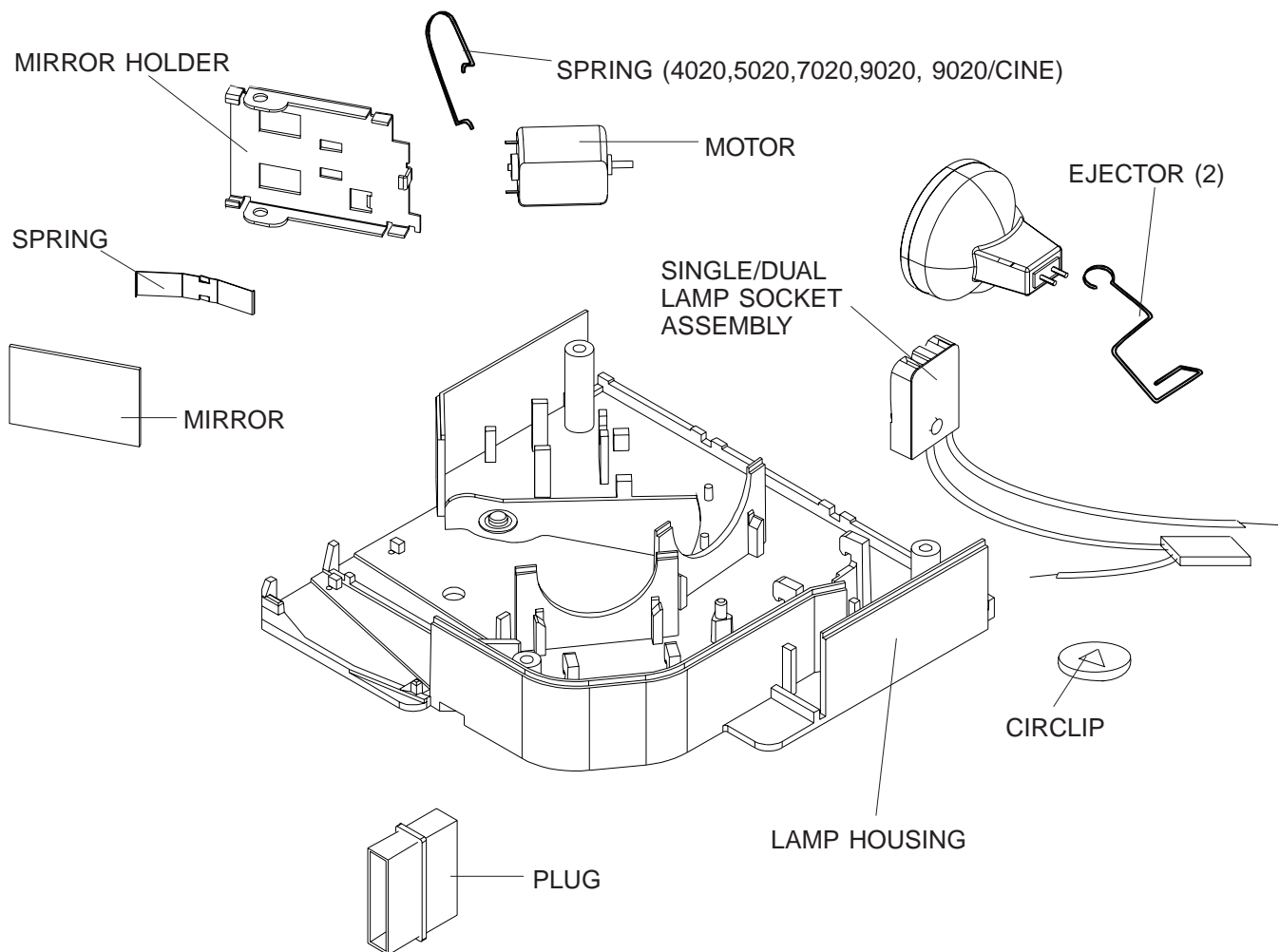

figure 4-33

DUAL LAMP MODULE**NOTE**

The SPRING in the DUAL LAMP MODULE has to be mounted without tension between the MIRROR and the MOTOR.

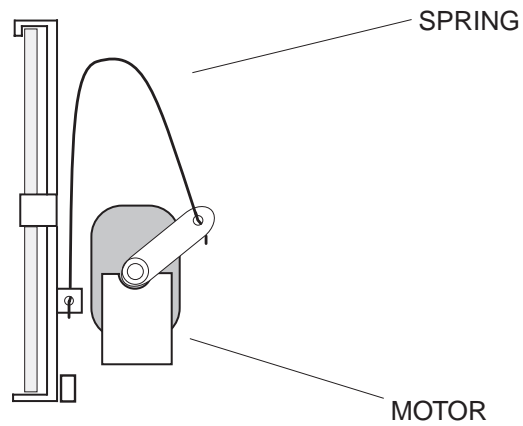

figure 4-34

Lubrication

Use the lubricant BARRIERTA L 25 DL (50g) No. 558 1960. Grease all arrow marked spots.

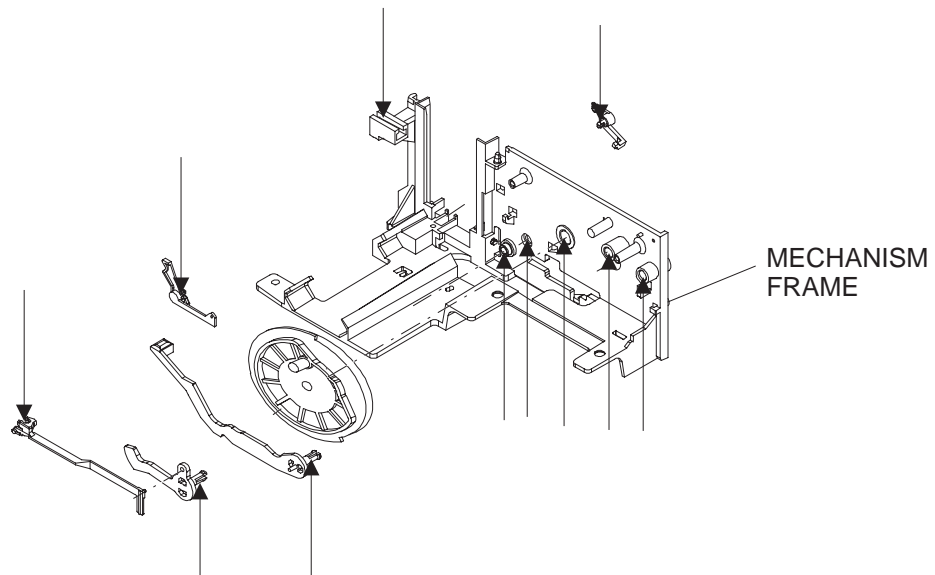

figure 4-35

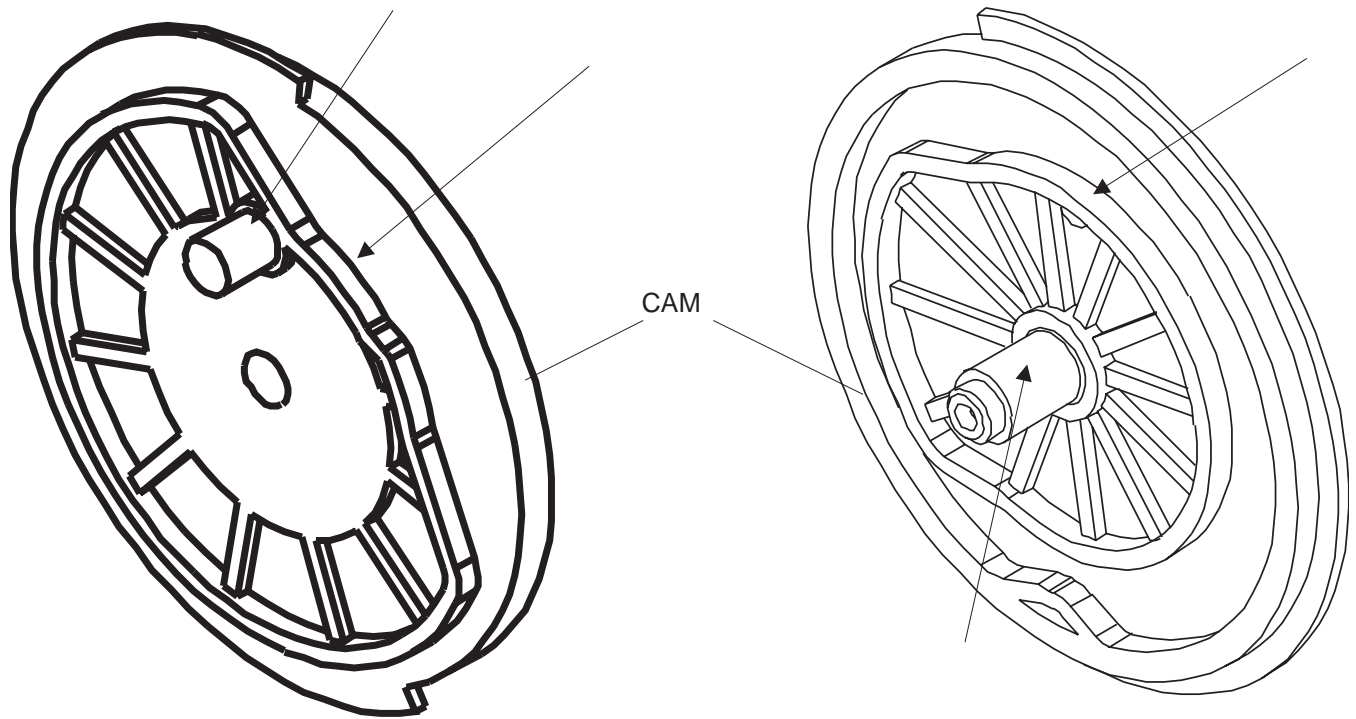

figure 4-36

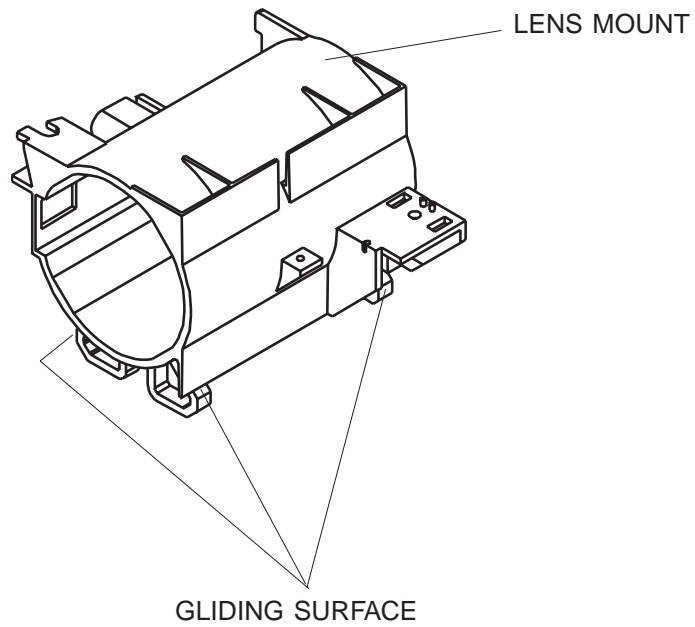
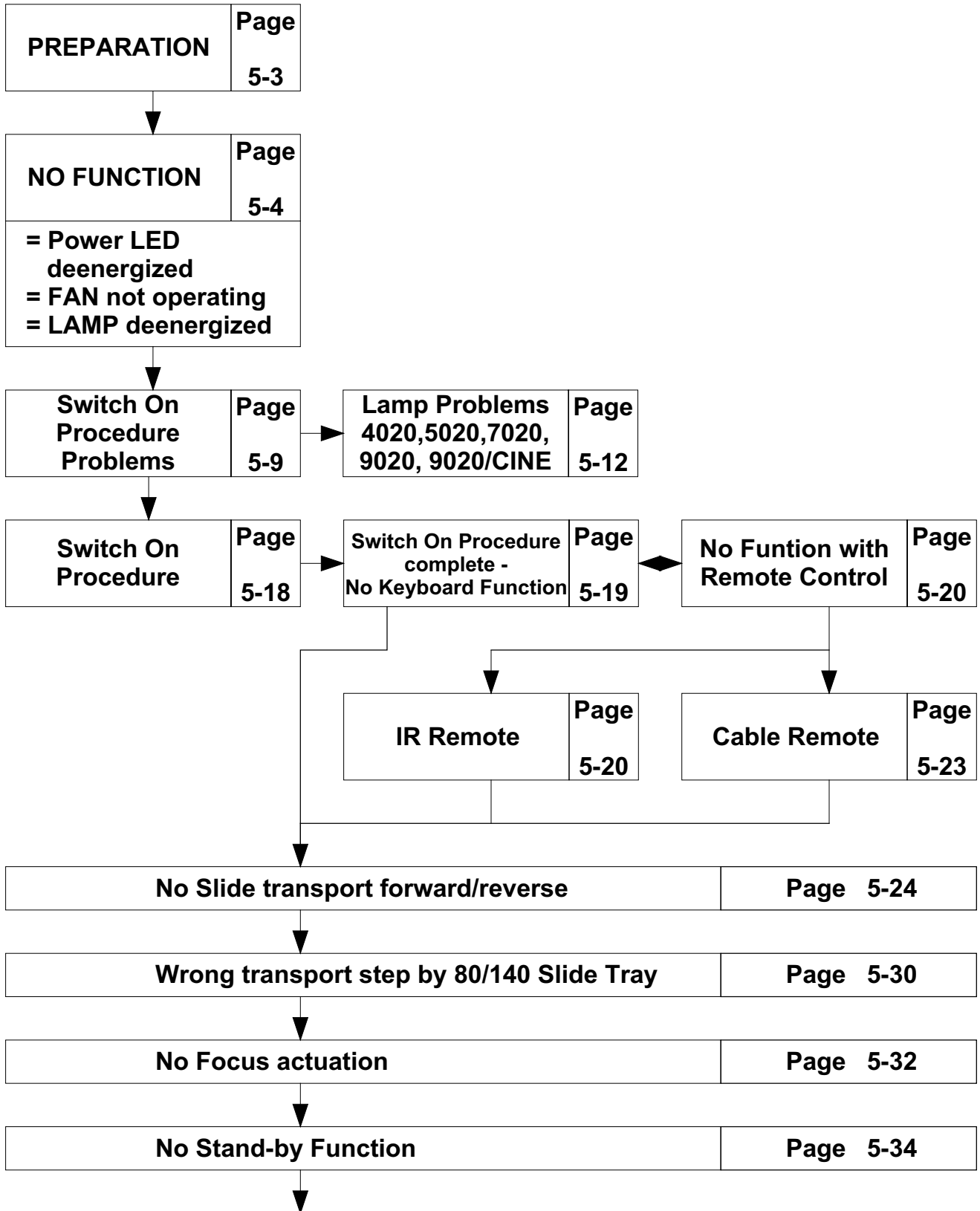

figure 4-37

5. DIAGNOSTICS

Diagnostic Overview EKTAPRO 4020/5020/7020/9020 and 9020/CINE



Communication Trouble 4020 - 9020 and 9020/CINE	Page 5-35
Autofocus 5020/9020/9029/CINE : No Autofocus Function	Page 5-38
Accessory Slot 7020/9020	Page 5-40

Preparation

Conditions:

- Ensure that line voltage does not vary more than +/- 5 % from the selected value on the projector.
- Insert a LAMP MODULE with a proper LAMP.
- Slide tray (80/140) with slide
- LENS (standard)
- Personal Computer / Lap top
- Interface Cable 9 PIN (Plug / socket)

No Function

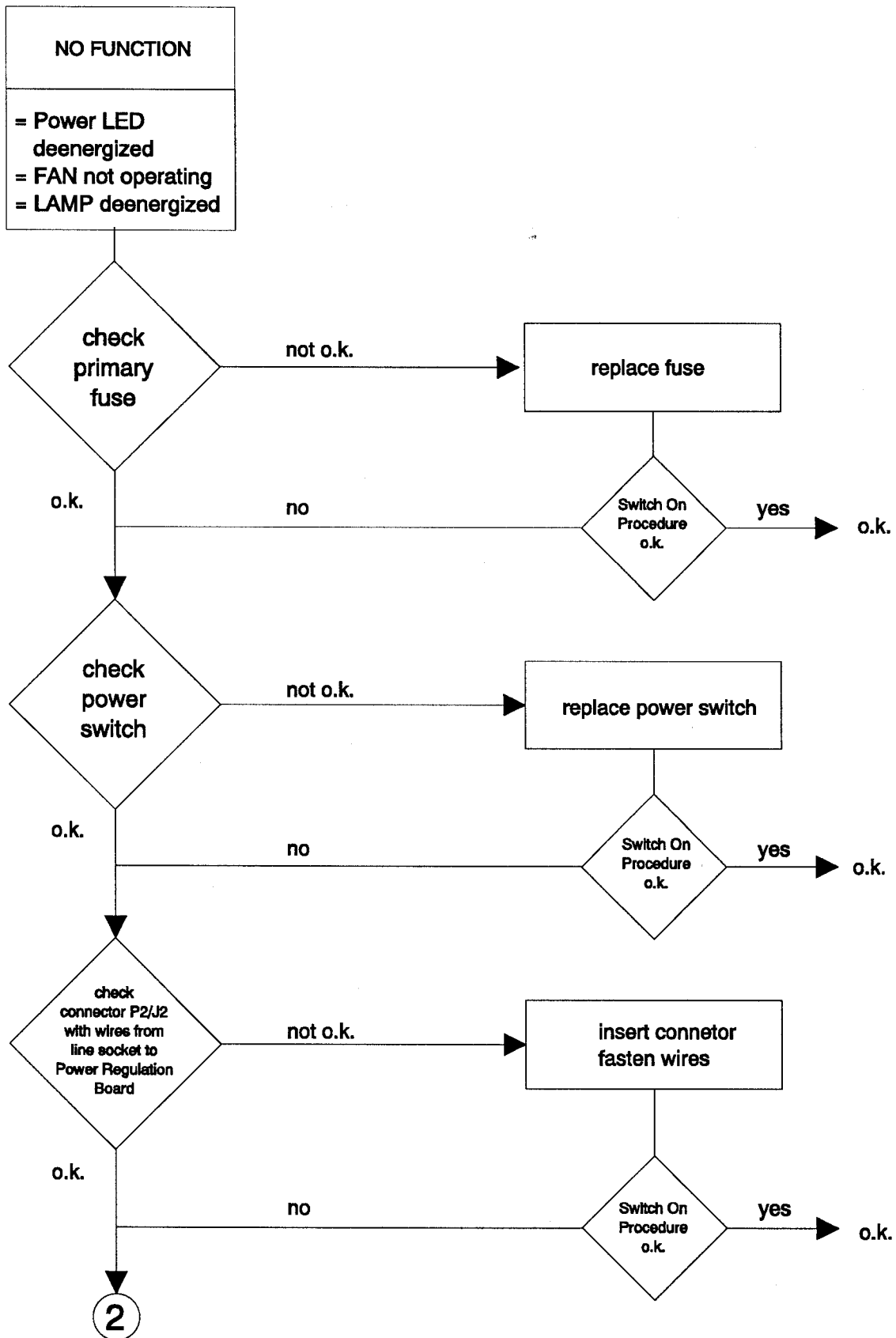

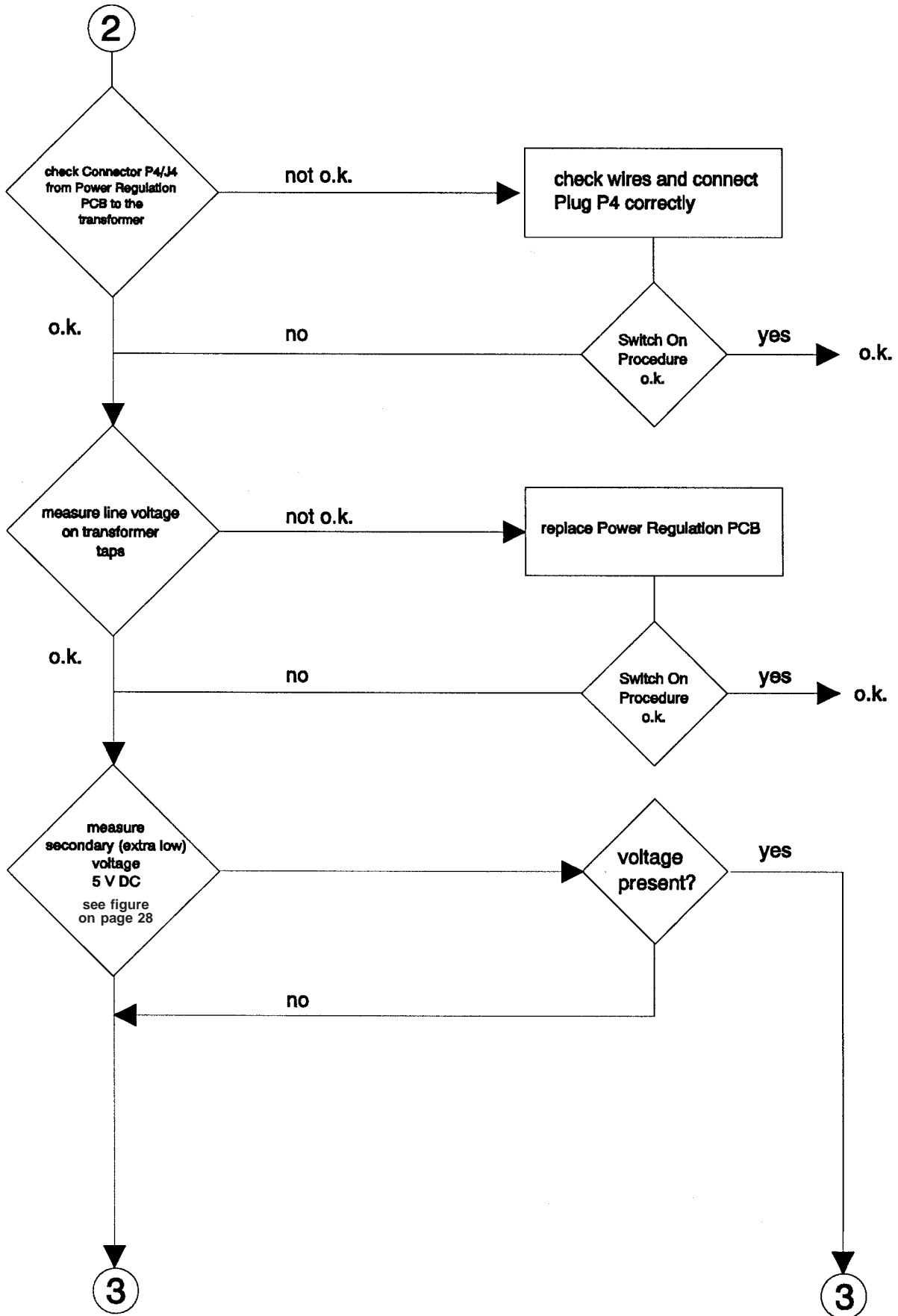

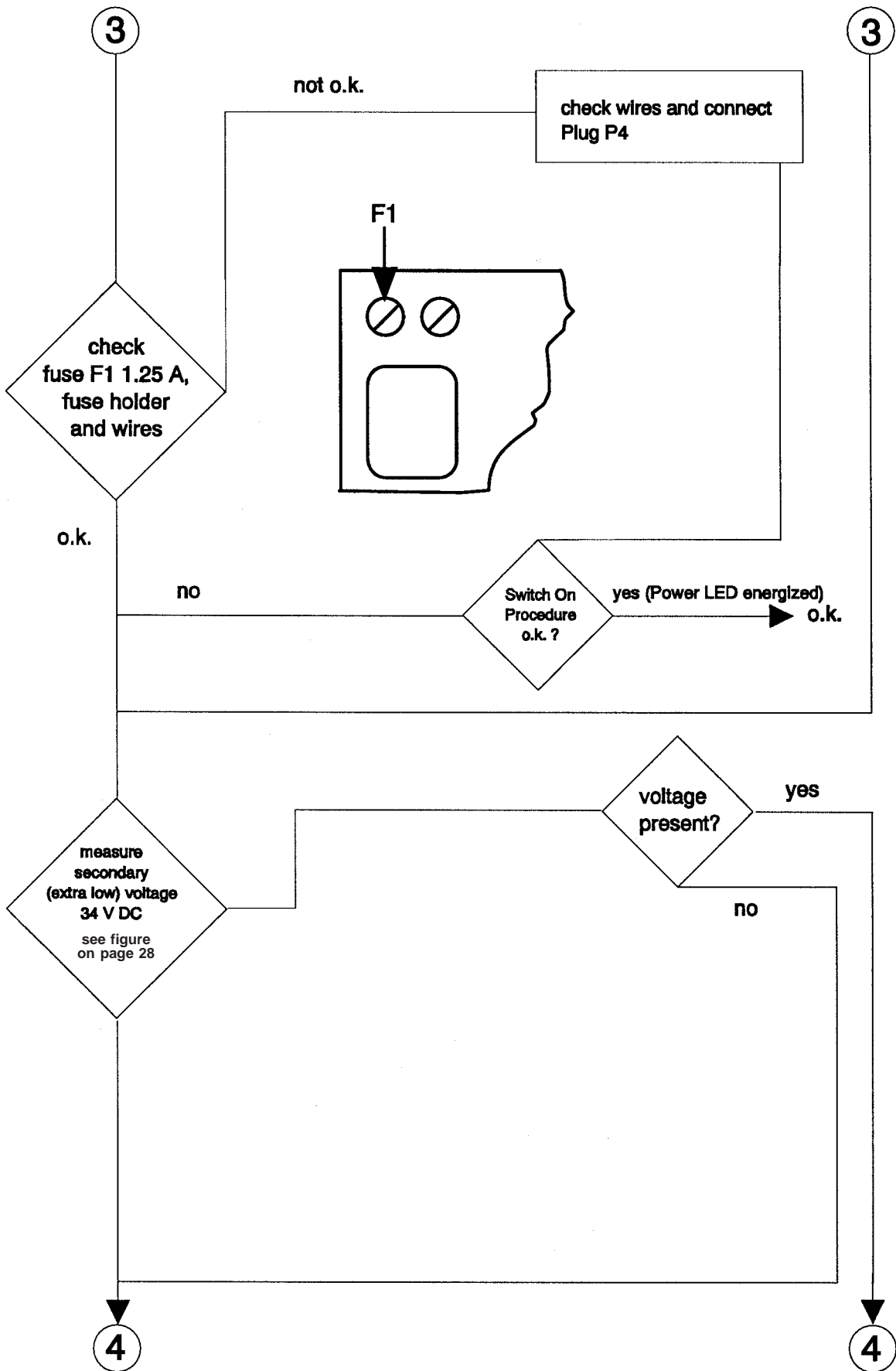

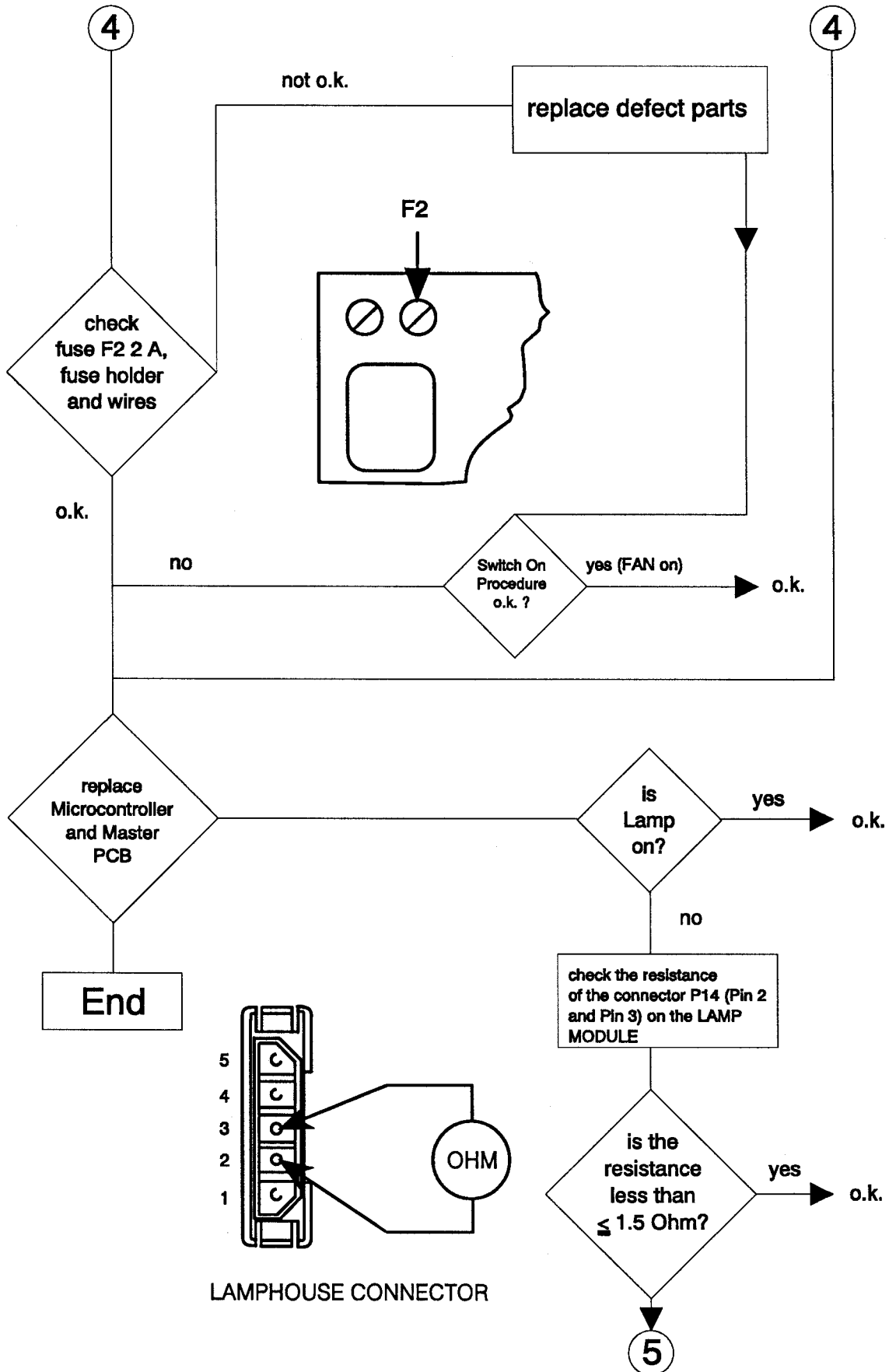

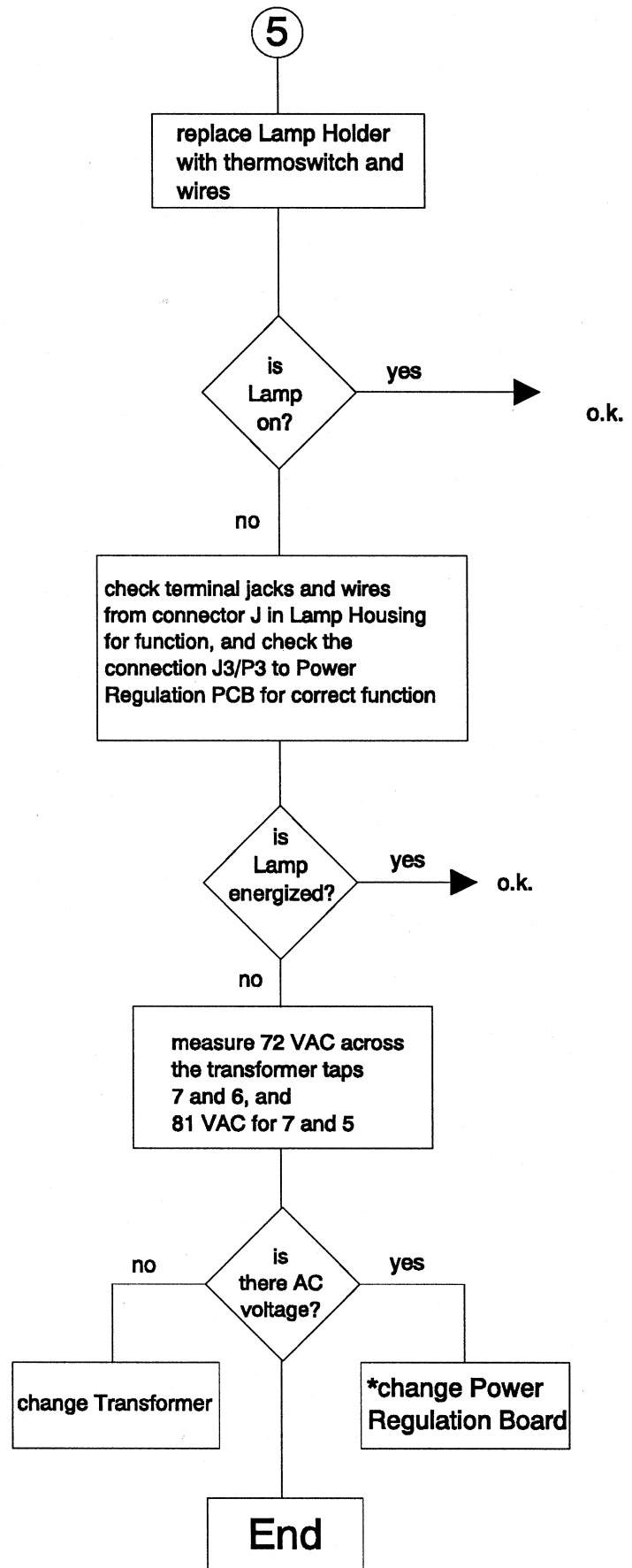

*
If the Power Board has been already changed in earlier steps, this procedure is not necessary.

Switch on Procedure Problems

Condition:

Slide Lifter Lever turns one revolution and stops (Power LED is flashing)

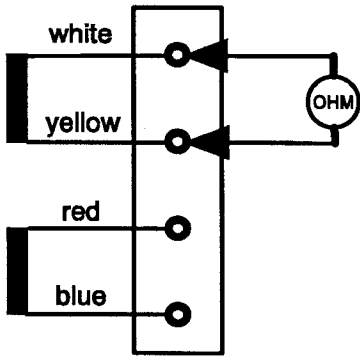

approx. 9 OHM

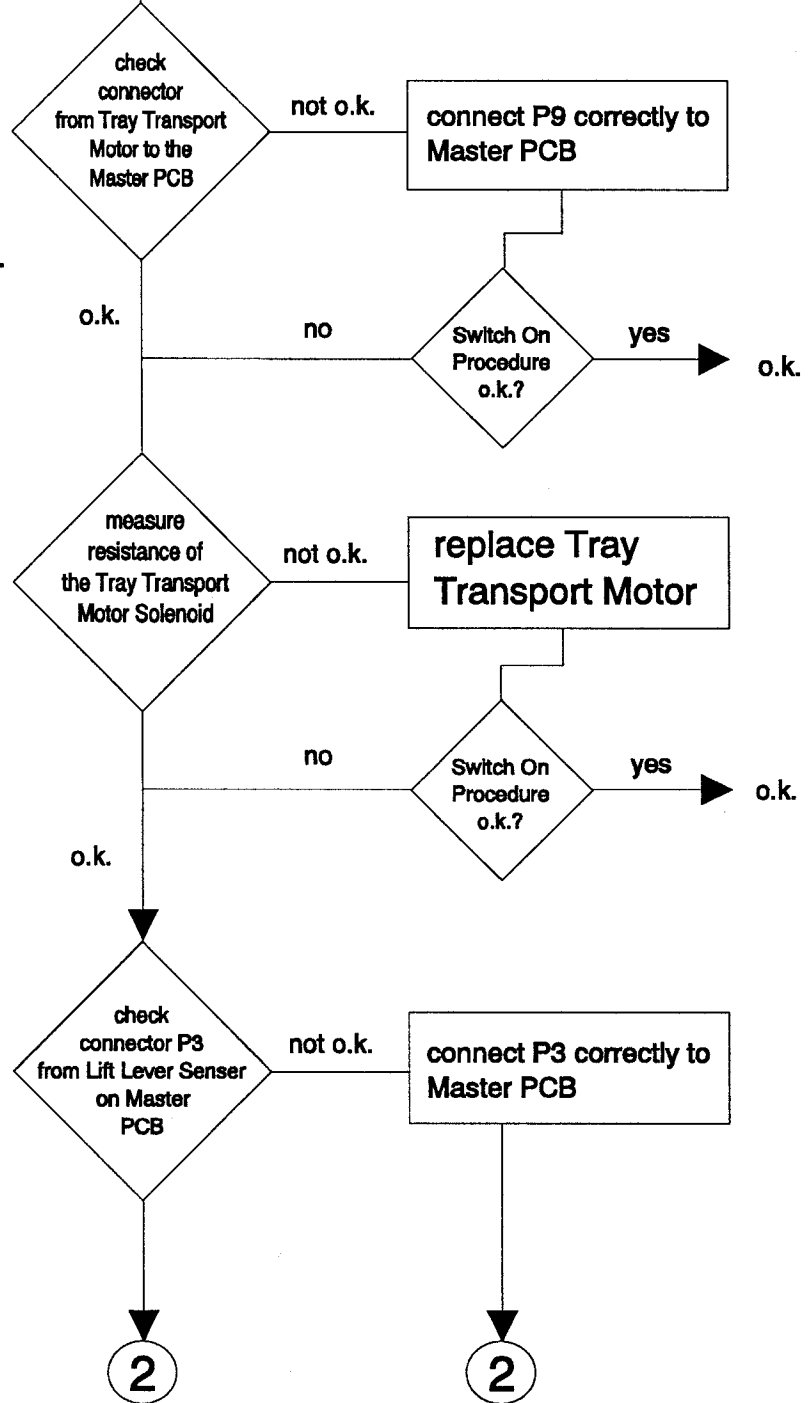

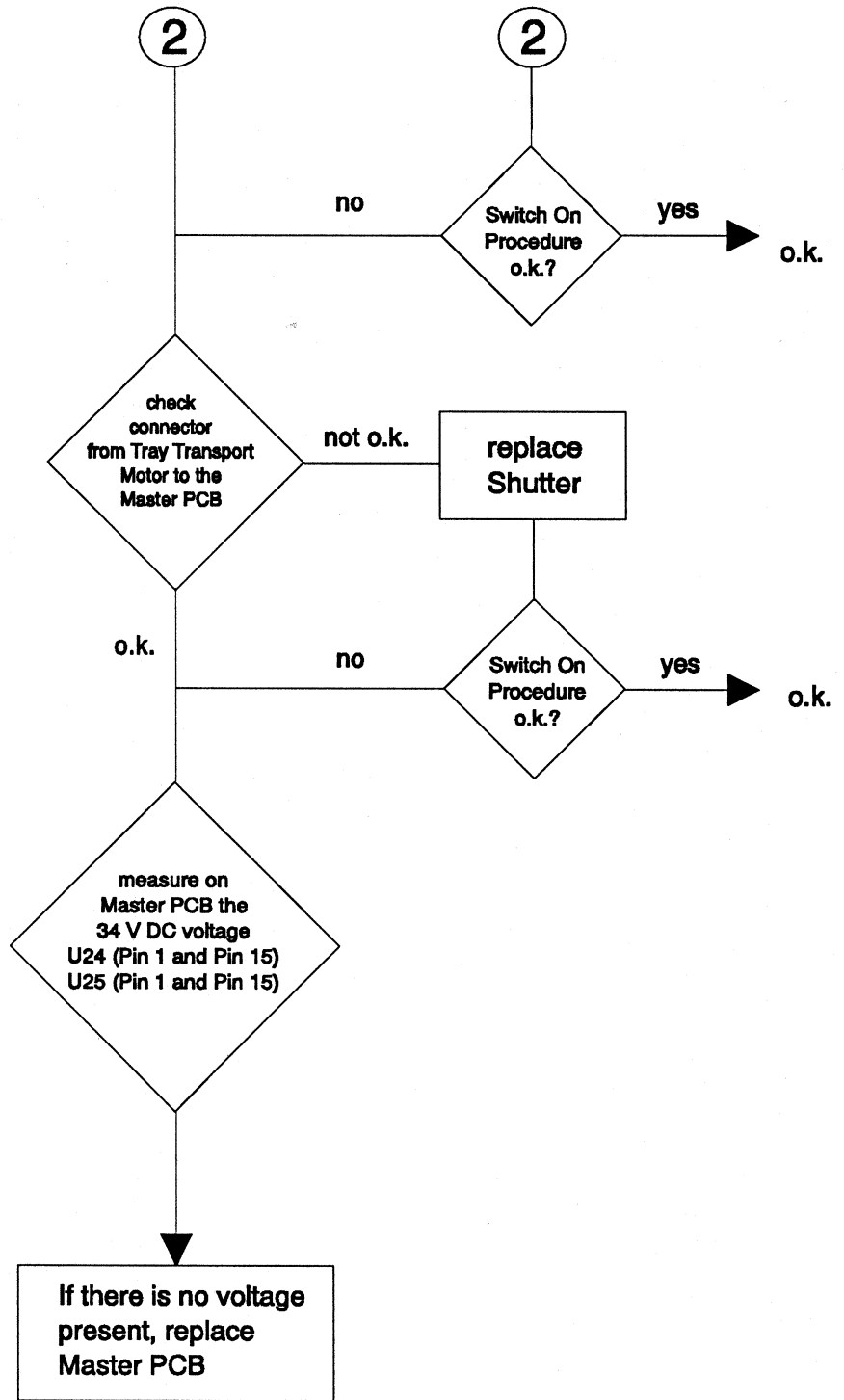
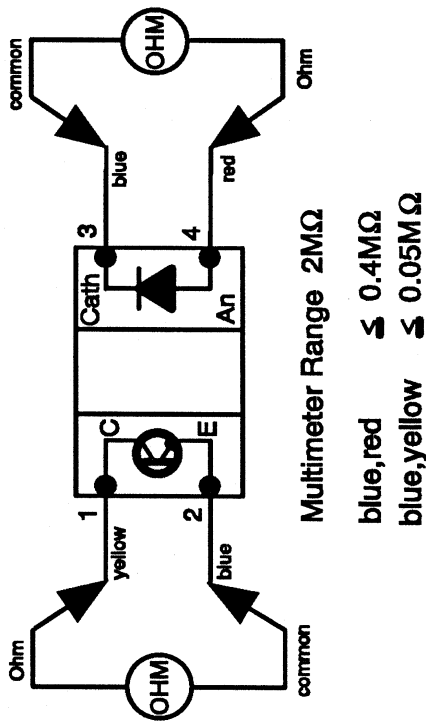

Condition:

**Slide Lift Lever stops in up position
but Tray Transport motor does not stop
at "zero"**

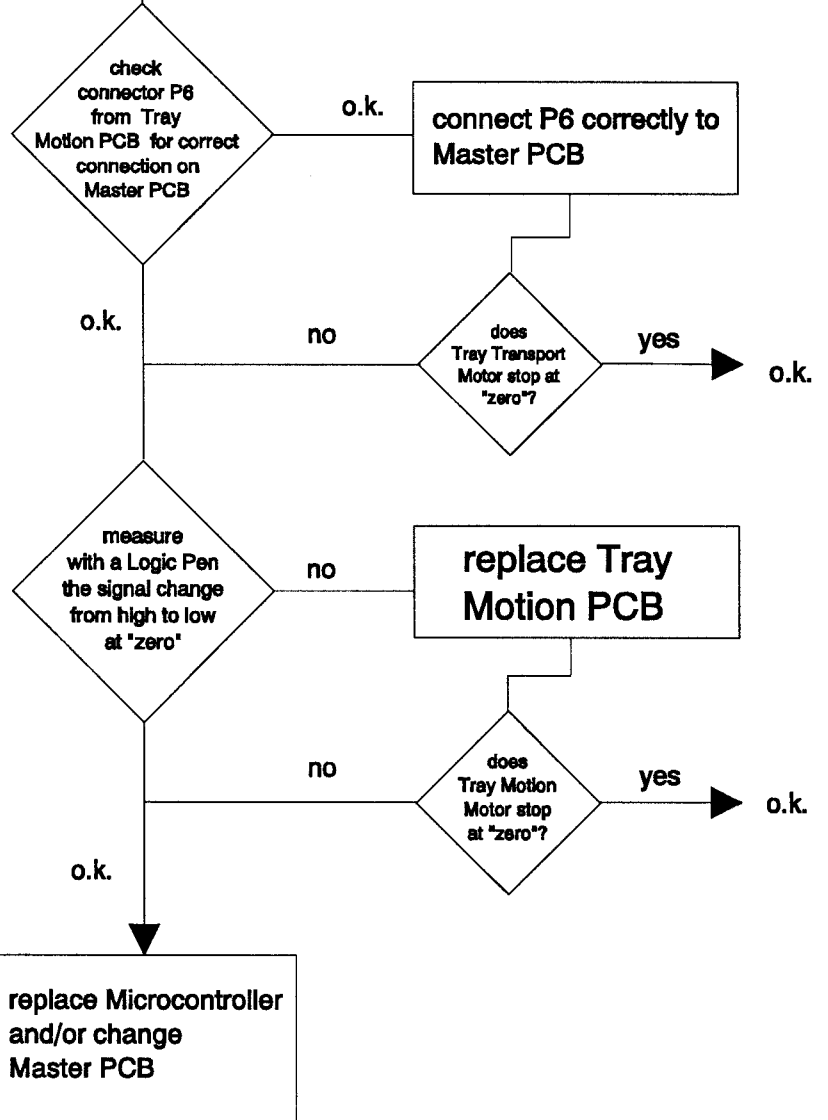
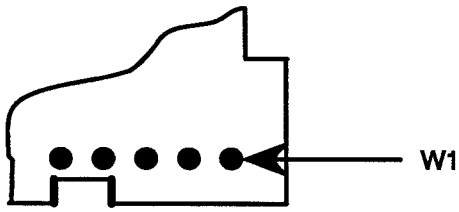

Lamp Problems 4020/5020/7020/9020 and 9020/CINE

Condition:

No " Lamp On" Function
Lamp LEDs on Backplate =ON

Check
Dual Lamp Module

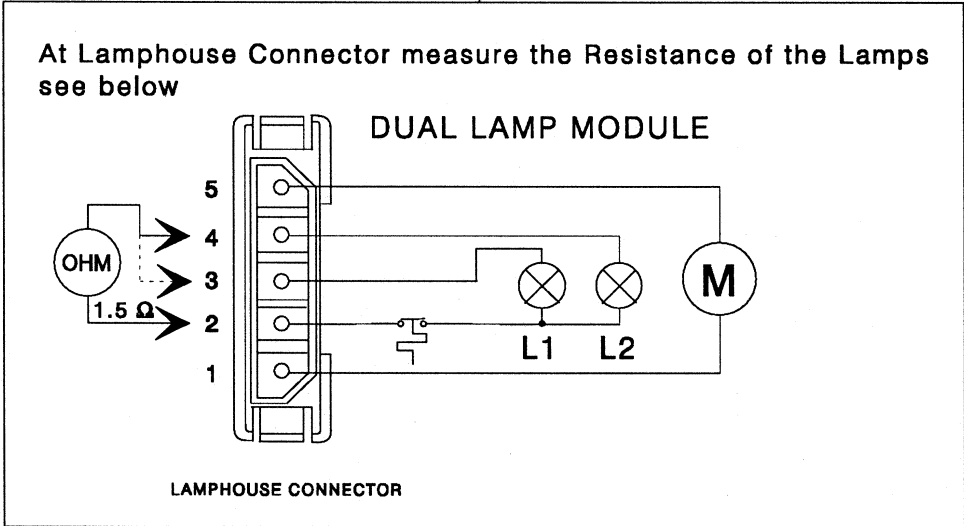

is
Resistance
≈ 1.5 Ohm
?

YES

Lamphouse OK.

NO

2

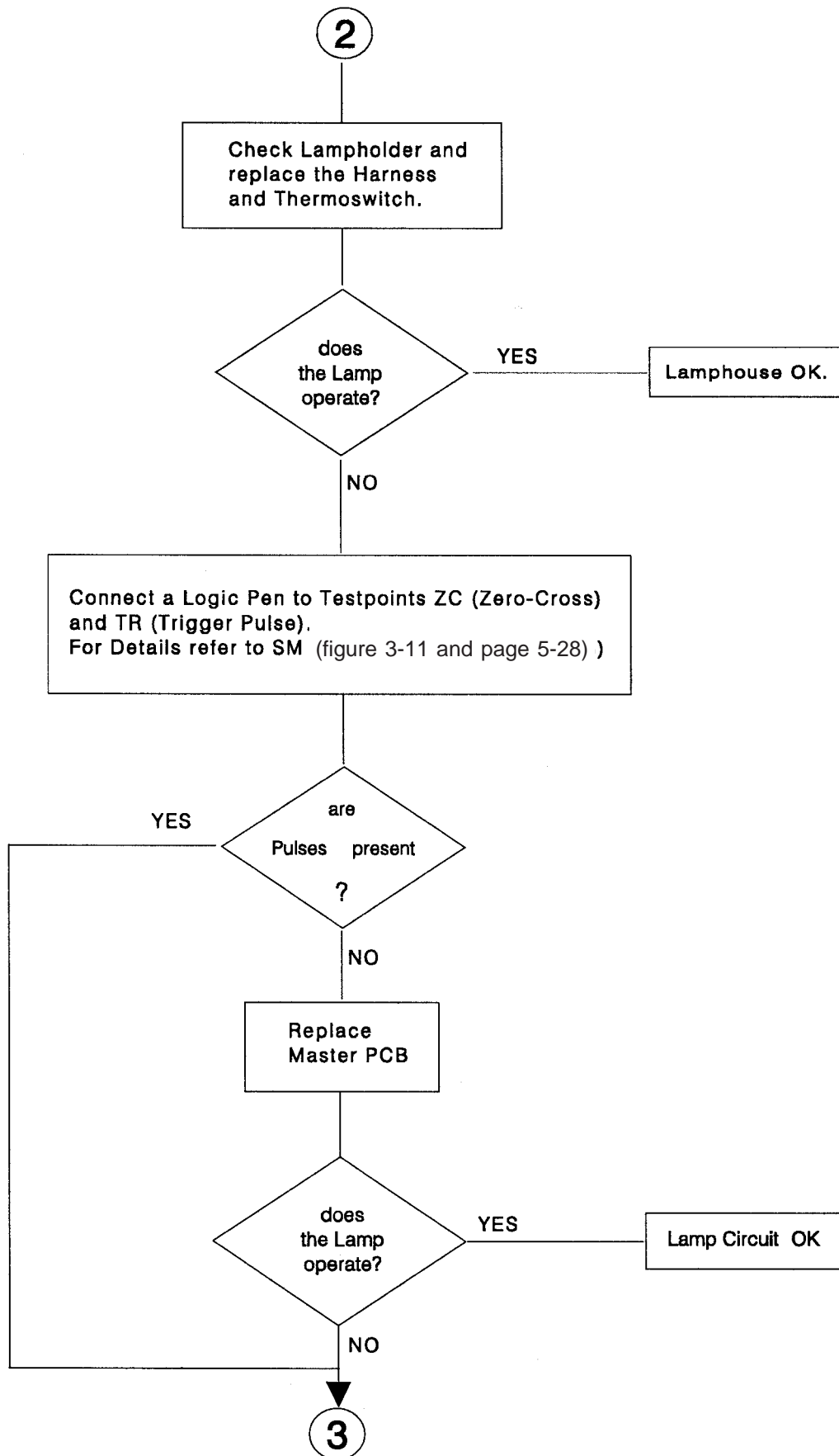

3

Measure the two Lamp Voltages 81V AC and 92V AC from the Transformer to J4 of the Power Regulation PCB. See below.

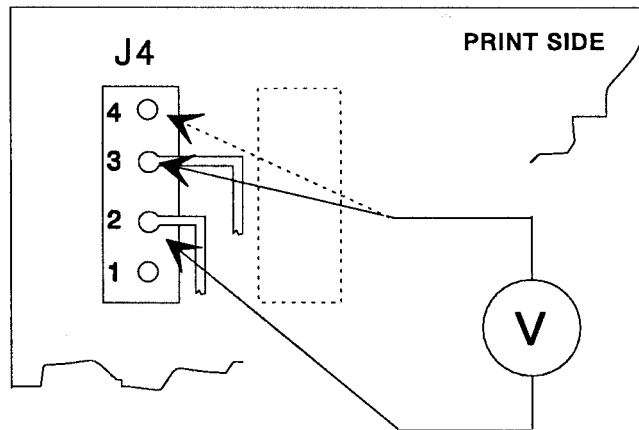

2 - 3 Low Lamp 81 V AC
2 - 4 Lamp 92 V AC

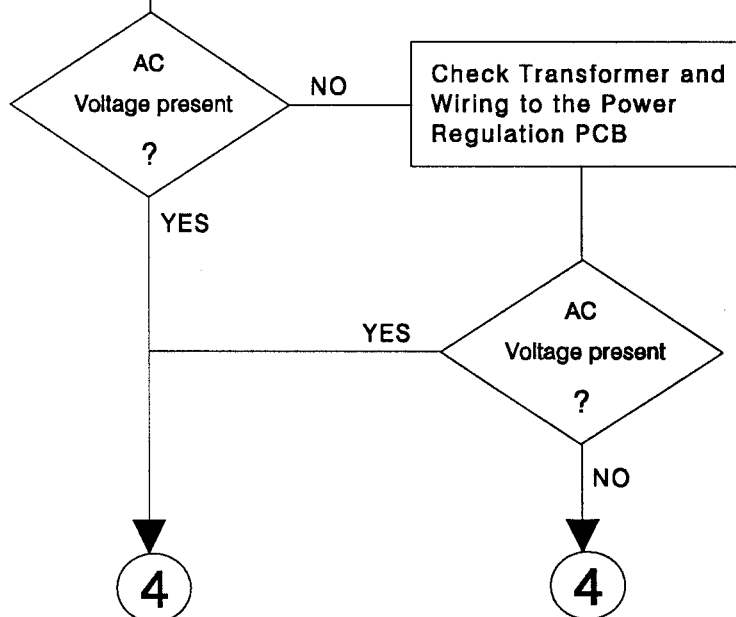

4

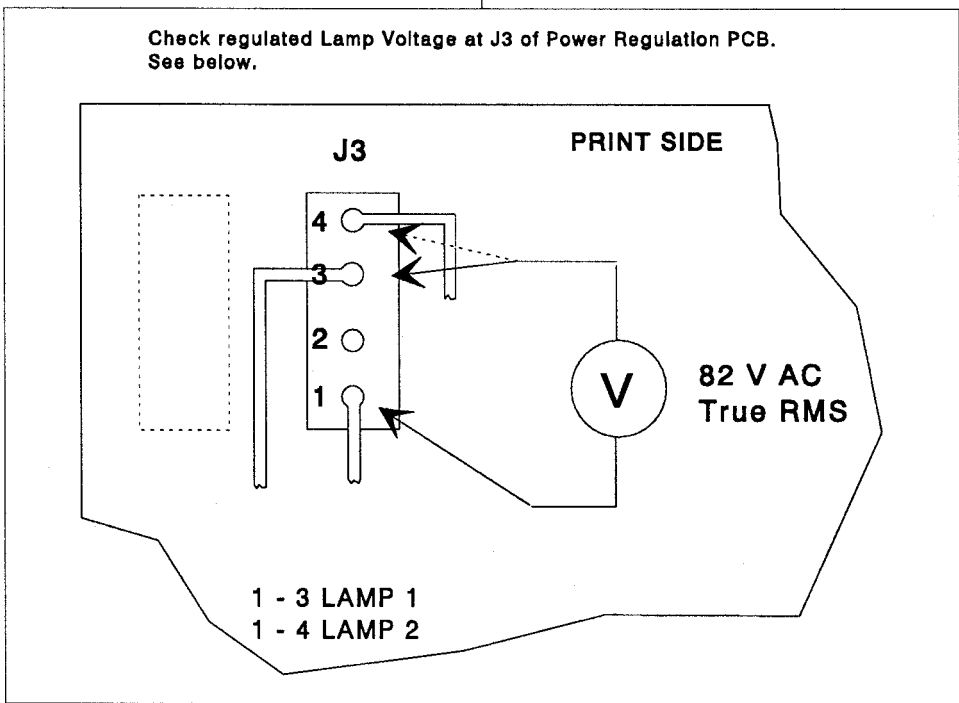
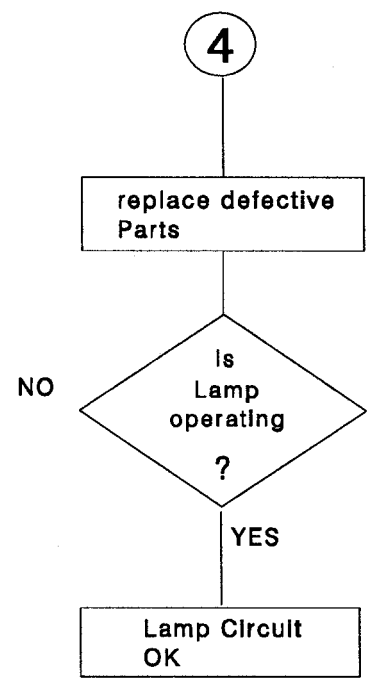

5

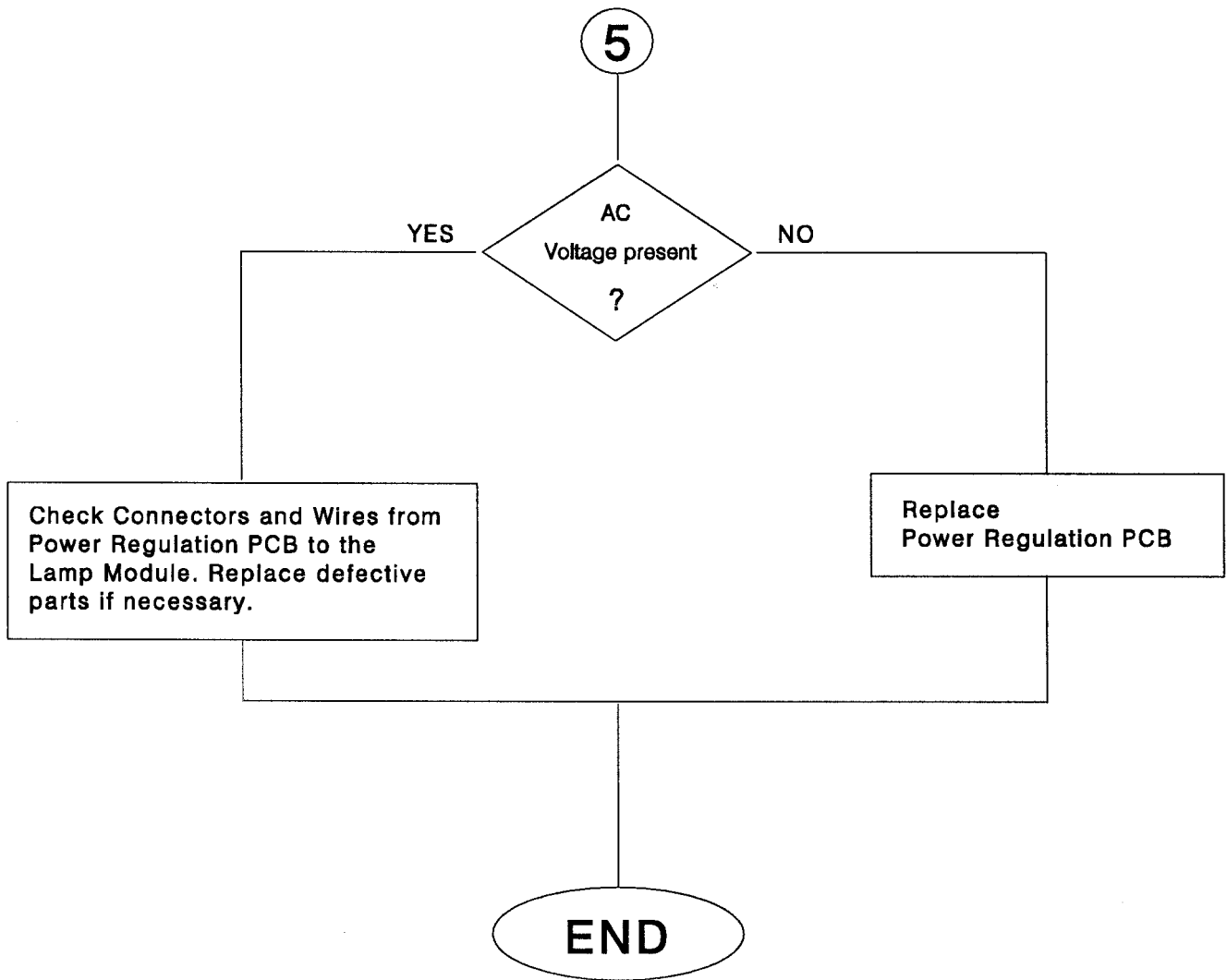

Mirror Position

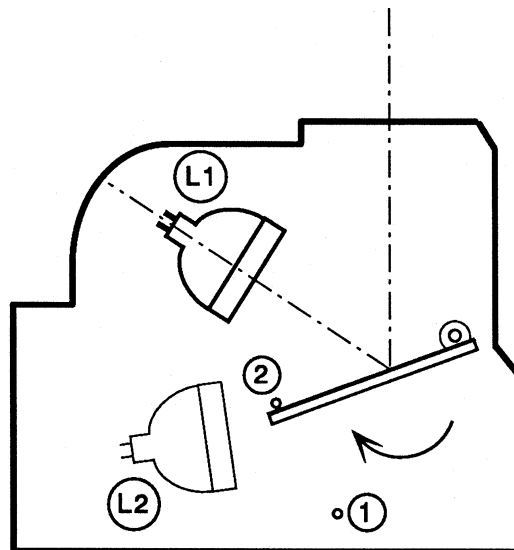
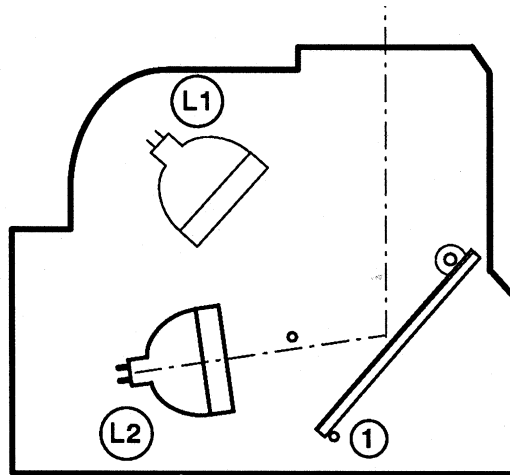

In the Service Software TL-4575 there is an option in the menu “Lamp toggle” to check the MIRROR FUNCTION and change the “lamp on” option. For the correct function in the projector, set the MIRROR to position 1 when Lamp 1 is active, or reset the projector.

If the MIRROR does not move by the software command, check the resistance of the MIRROR DC MOTOR (see figure) and measure the 34 VDC voltage on the MASTER PCB if necessary.

Brightness Test

Use the option “Adjust Brightness” from the Service Software TL-4575 to dim the PROJECTOR LAMP. There is a range from “0” (dark) to “1000” (bright), in steps of 10 units. With the “Reset” command in the main menu the original brightness can be reset.

Switch On Procedure

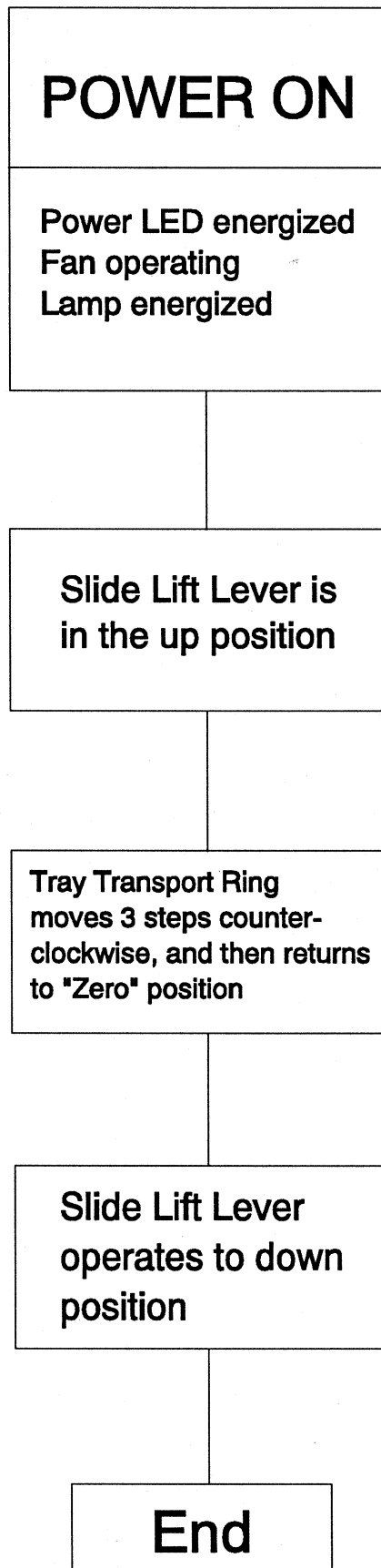

Switch On Procedure complete - No Keyboard Function

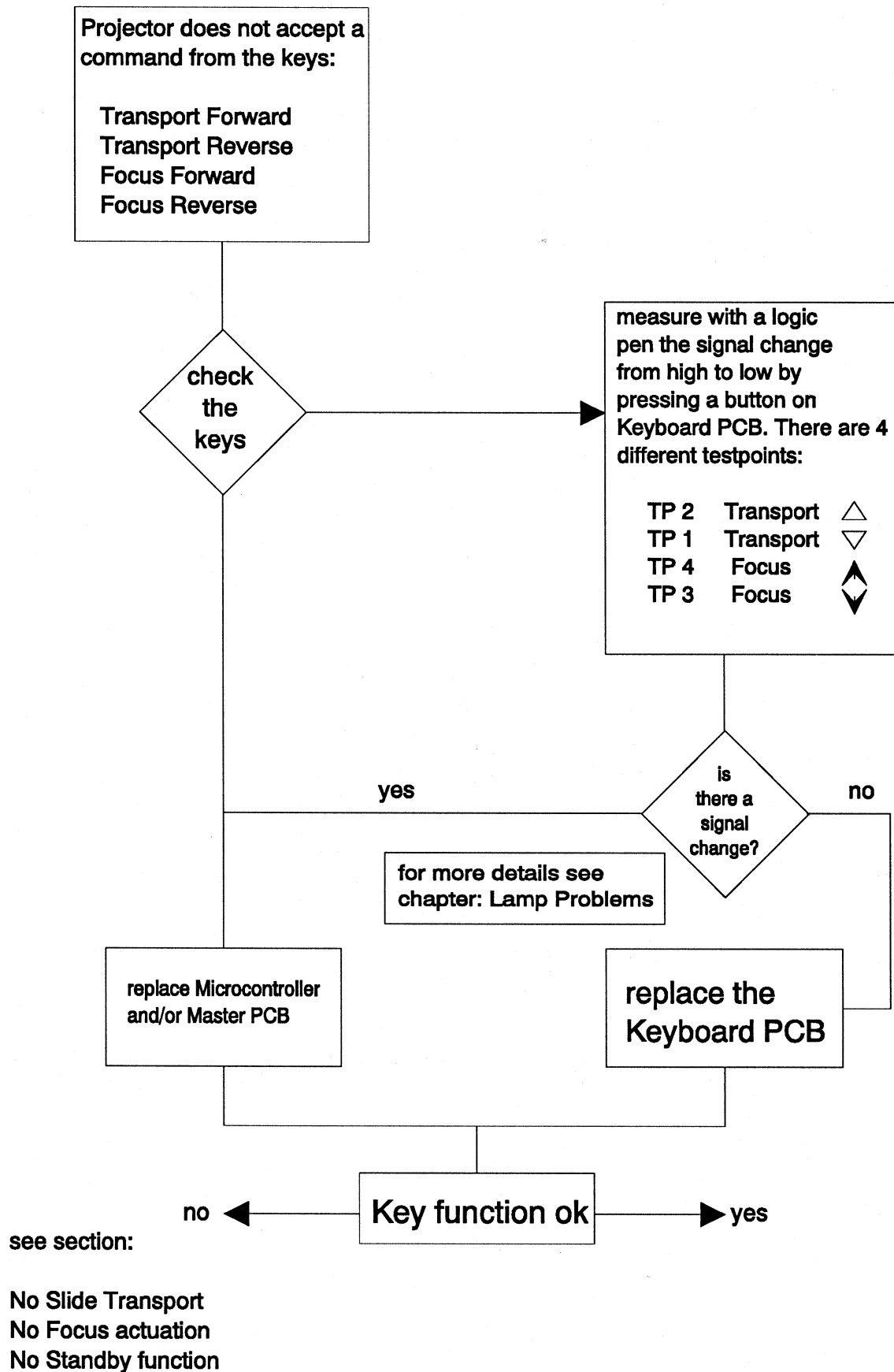

No function with REMOTE CONTROL

IR Remote Control

Condition:

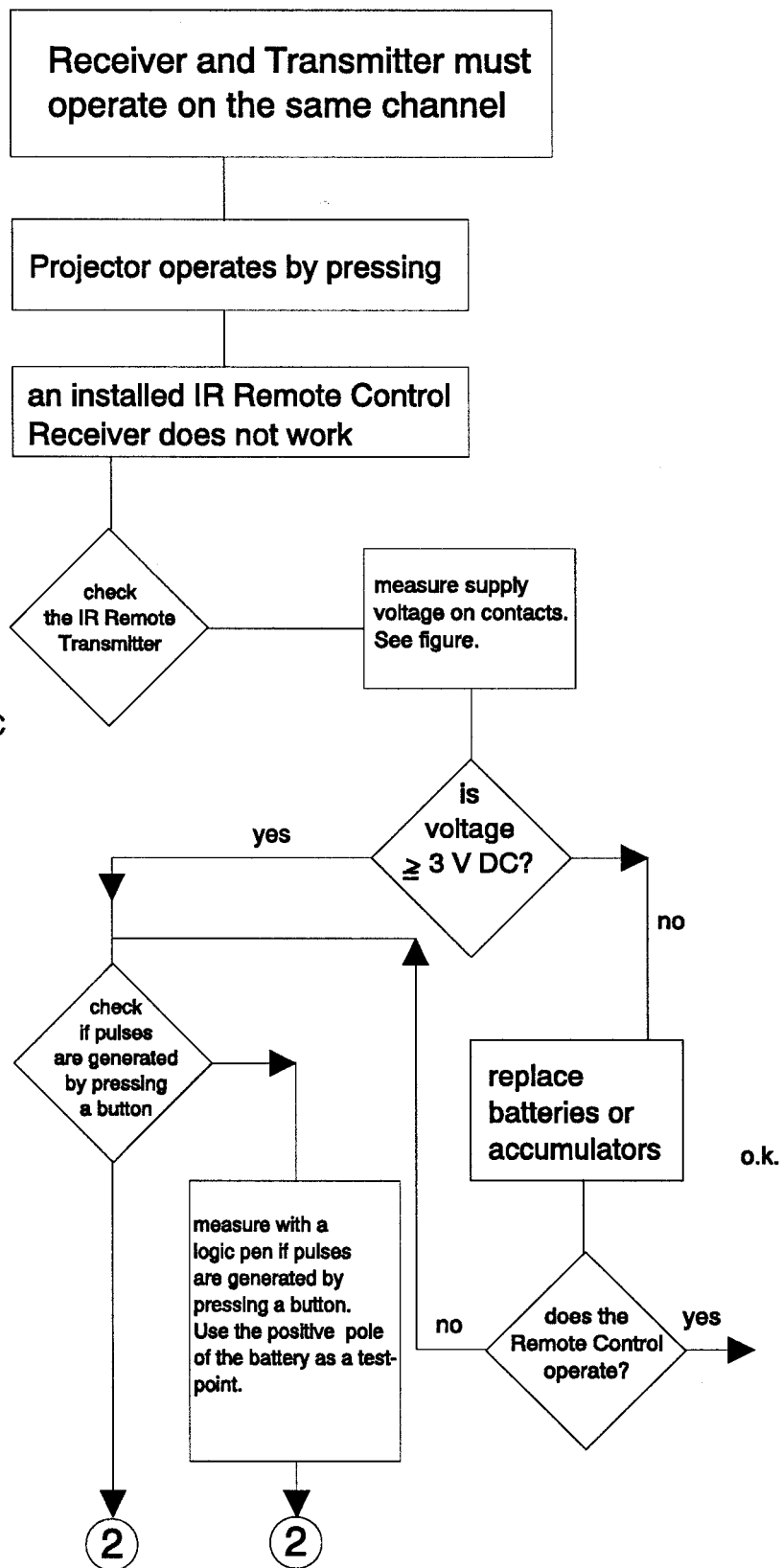

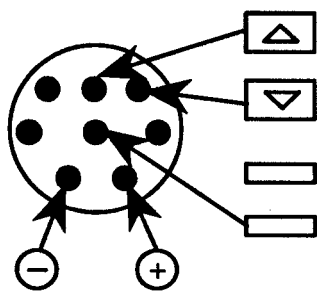
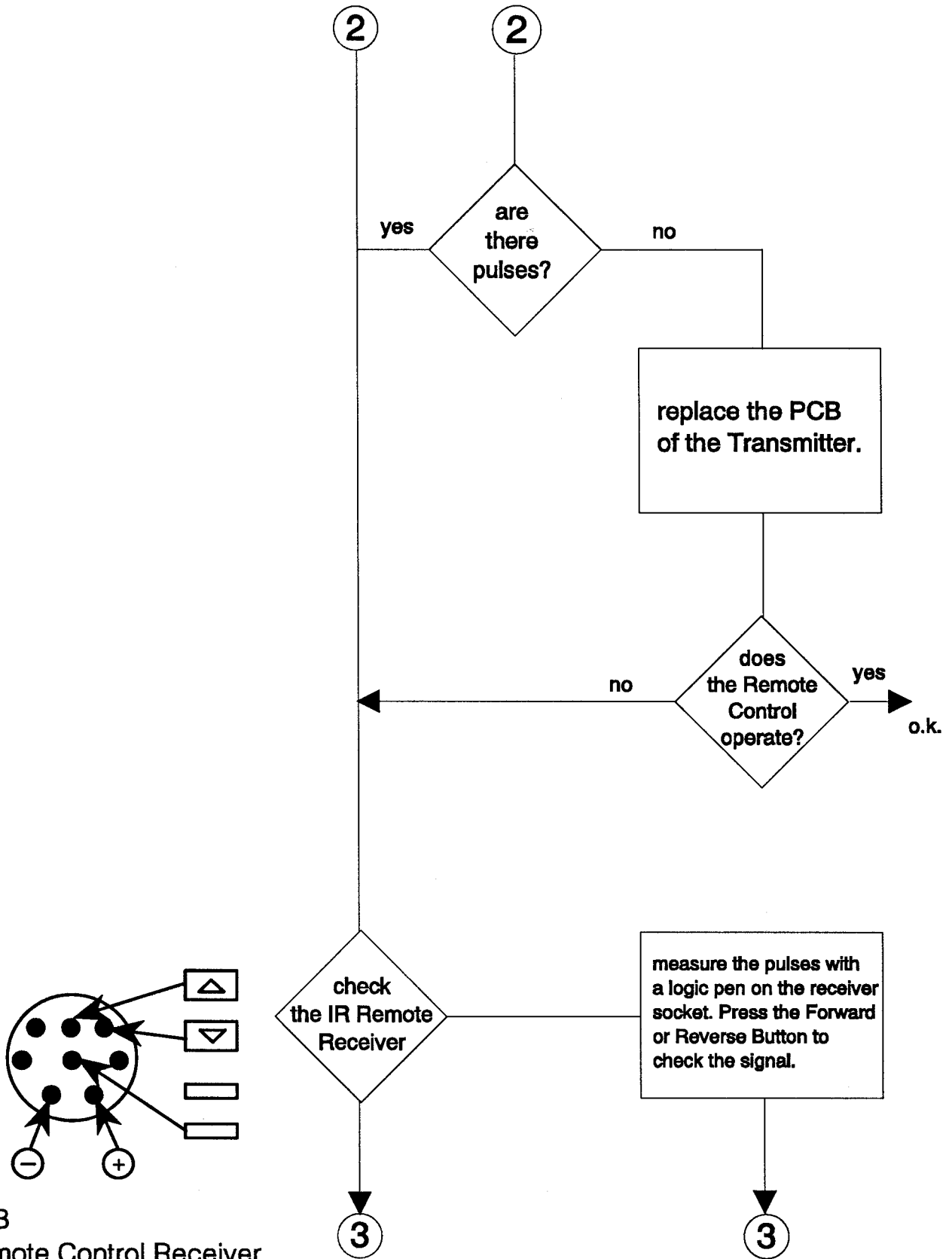

PCB Remote Control Receiver

View to Print Side

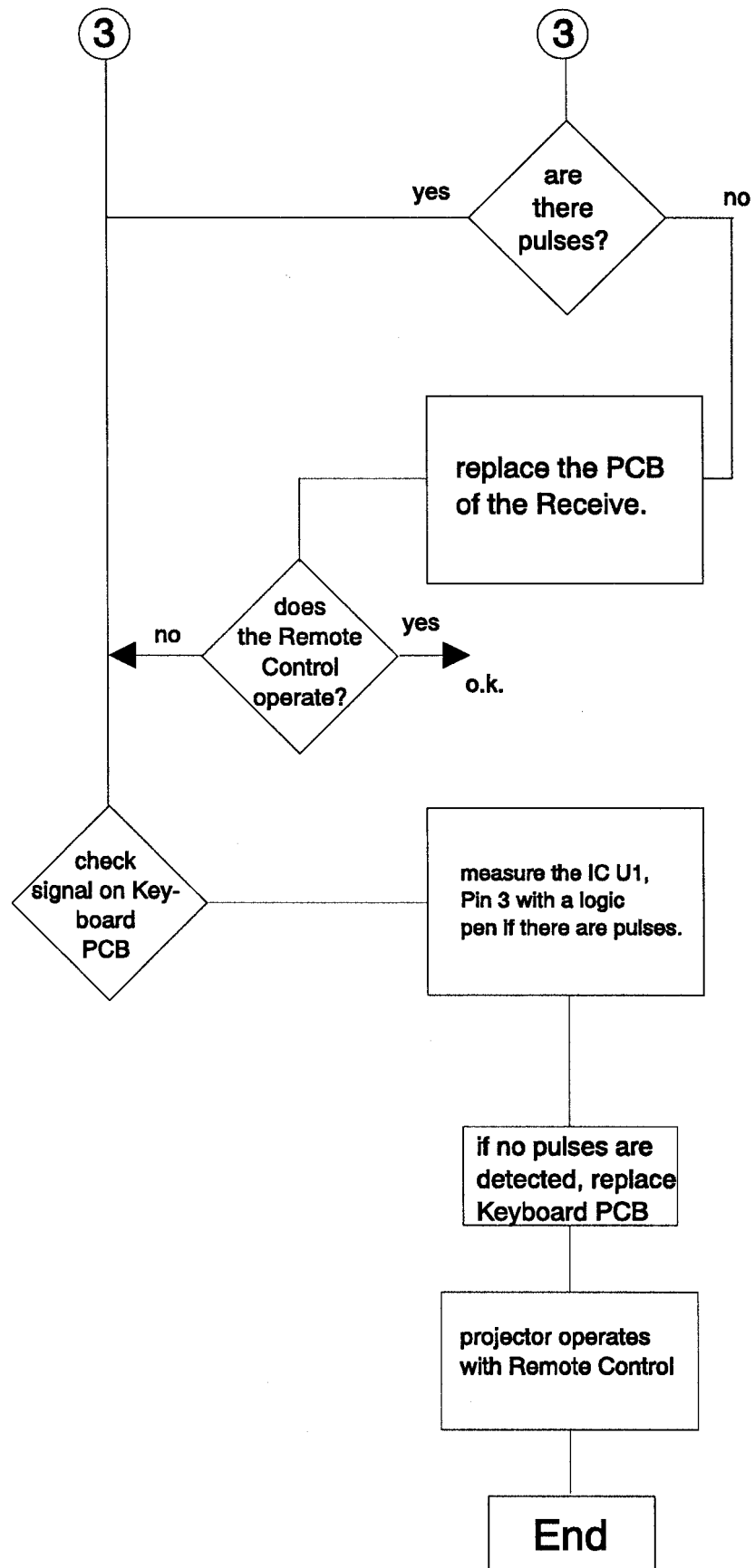

Cable Remote

Condition:

The Button Function of the projector operates

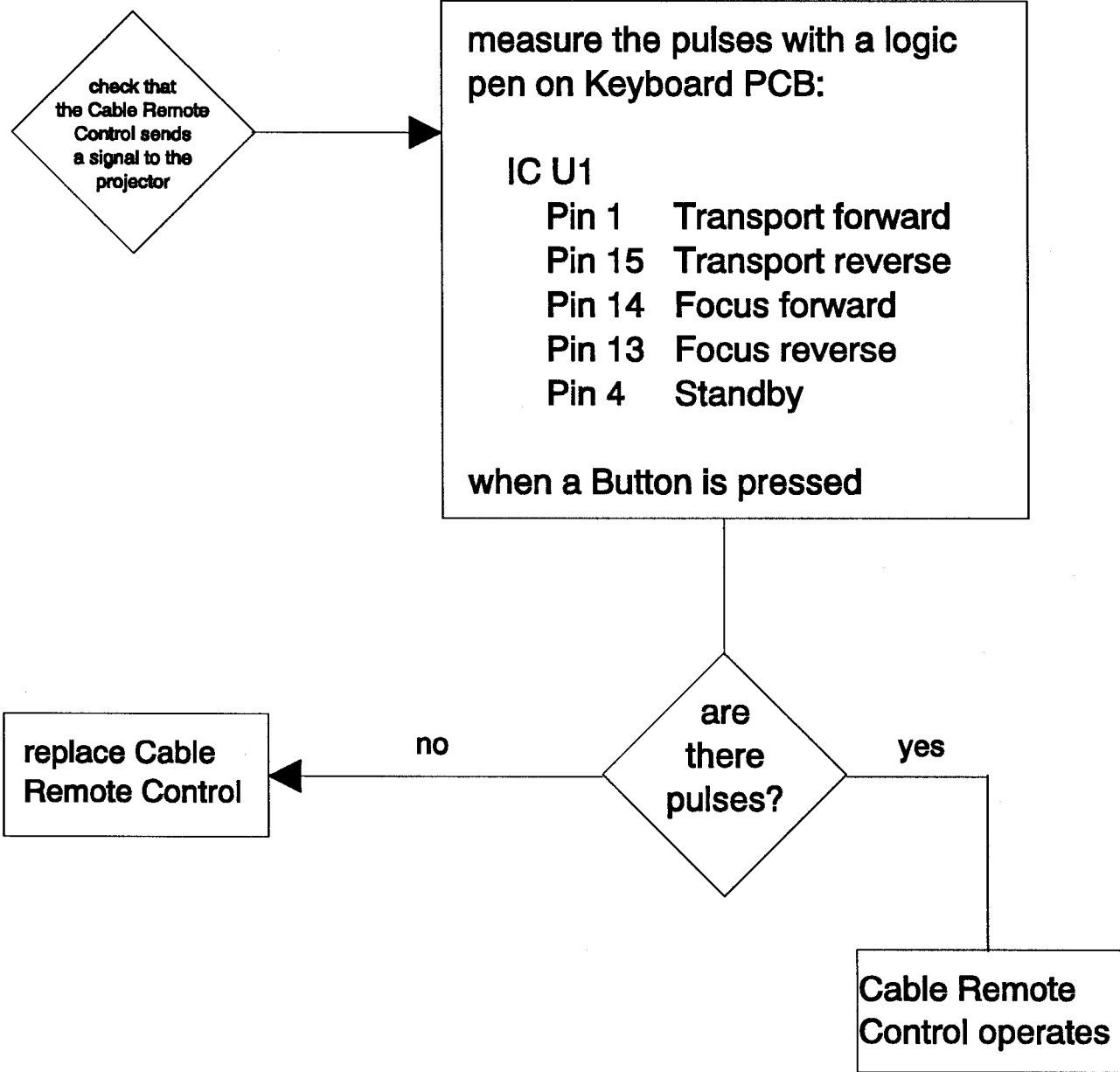

No Slide Transport forward/reverse and other projection problems

Condition:

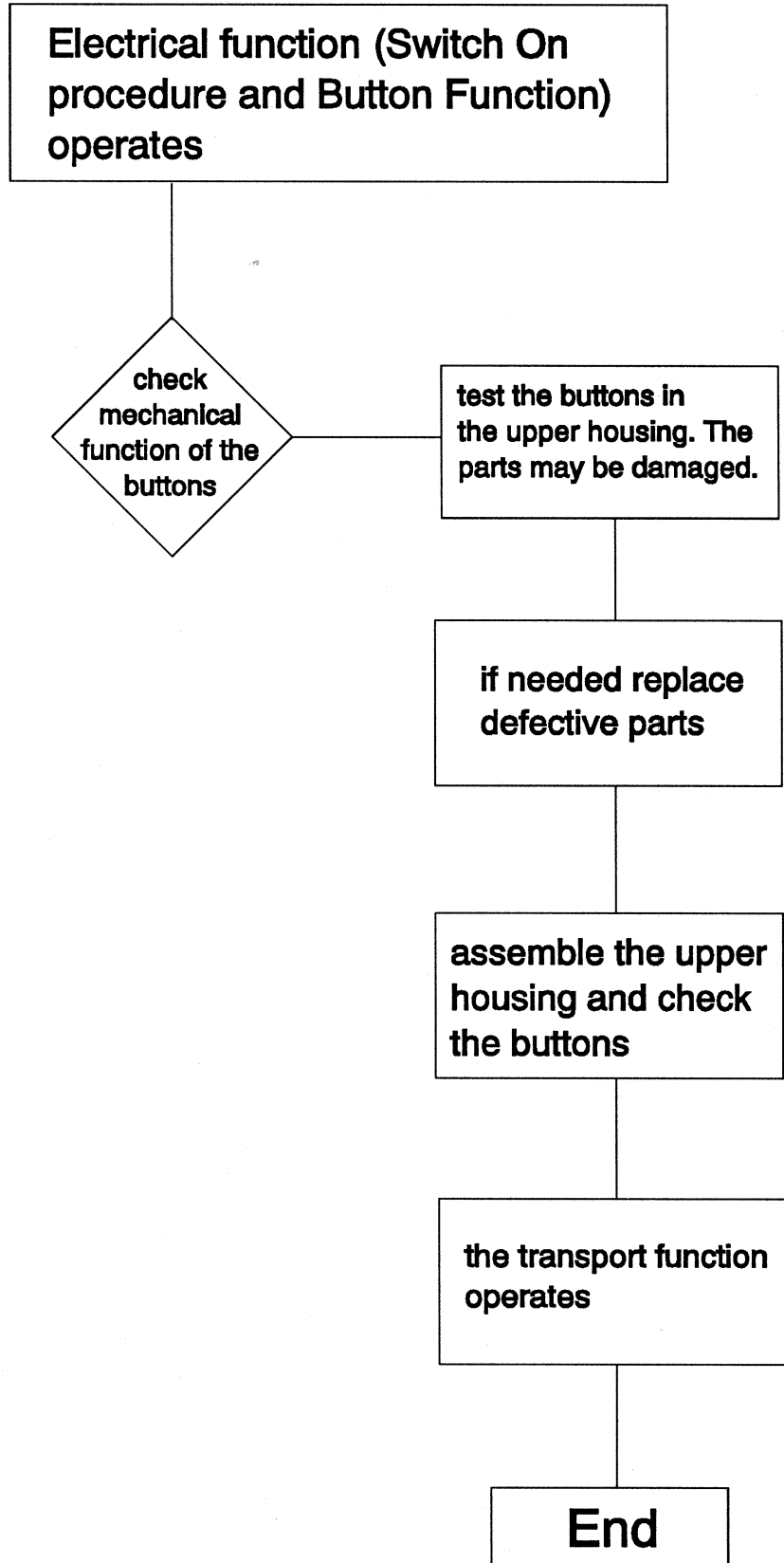

Shutter Problems

Condition:

Slide Transport with a Slide Tray and slides operate

the Shutter is does not open when a slide remains is in the gate

check the Shutter Soldenoid

remove Connector P12 and measure the resistance of the Magnet

is the resistance appr. 35 ohm?

replace the Magnet

measure J12 on Master PCB for 34 VDC

does the Shutter operate? *

2

an easy method to actuate the Shutter is:

Simulate a slide with a piece of plastic. Press the FORWARD/ REVERSE Button. While the Slide Lifter is going down, place the slide in position. Note, the slide must be in position before a cam cycle is completed.

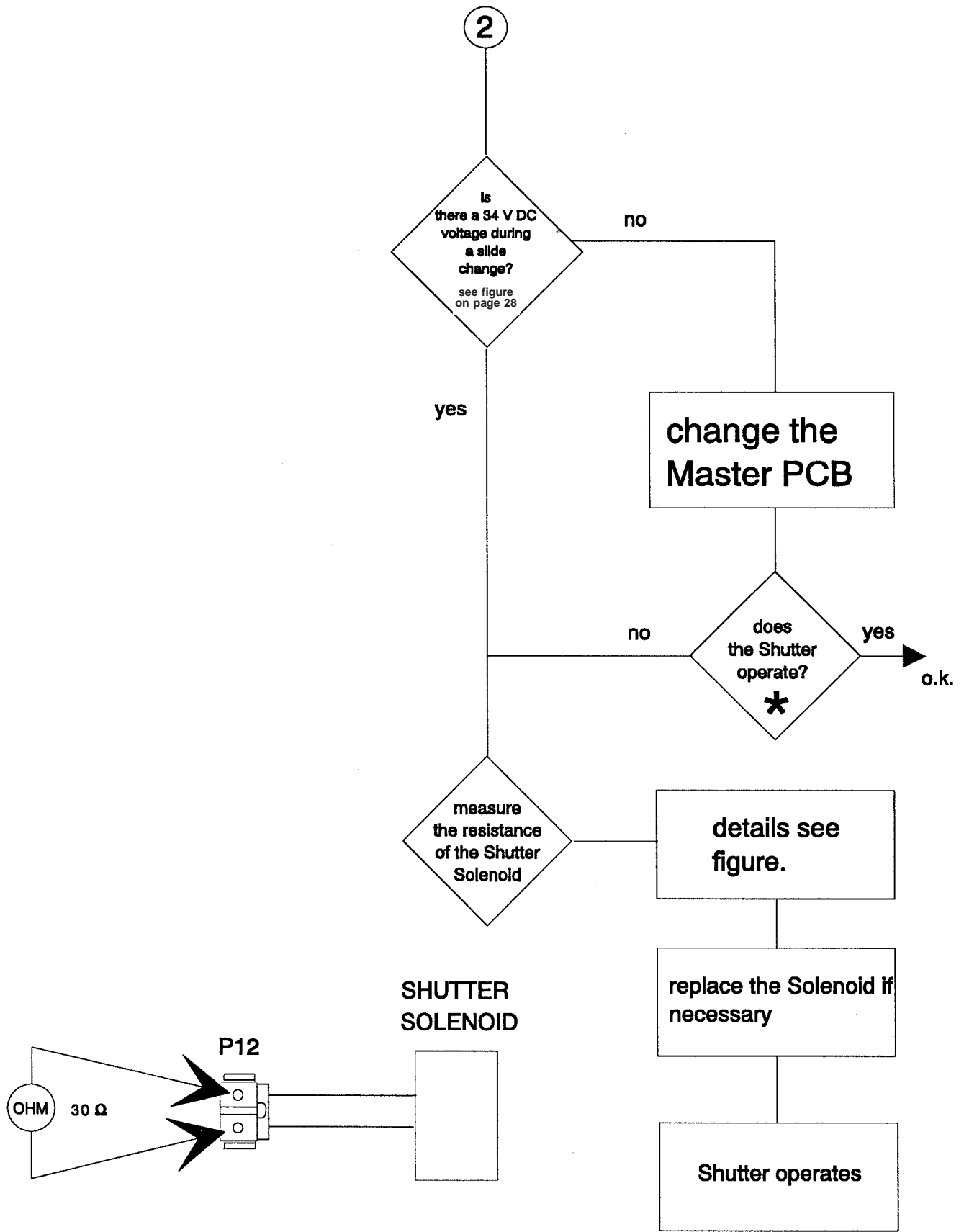

Fan Problems

Condition:

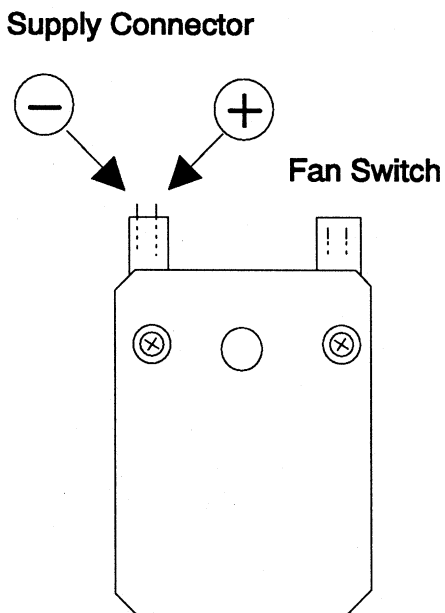
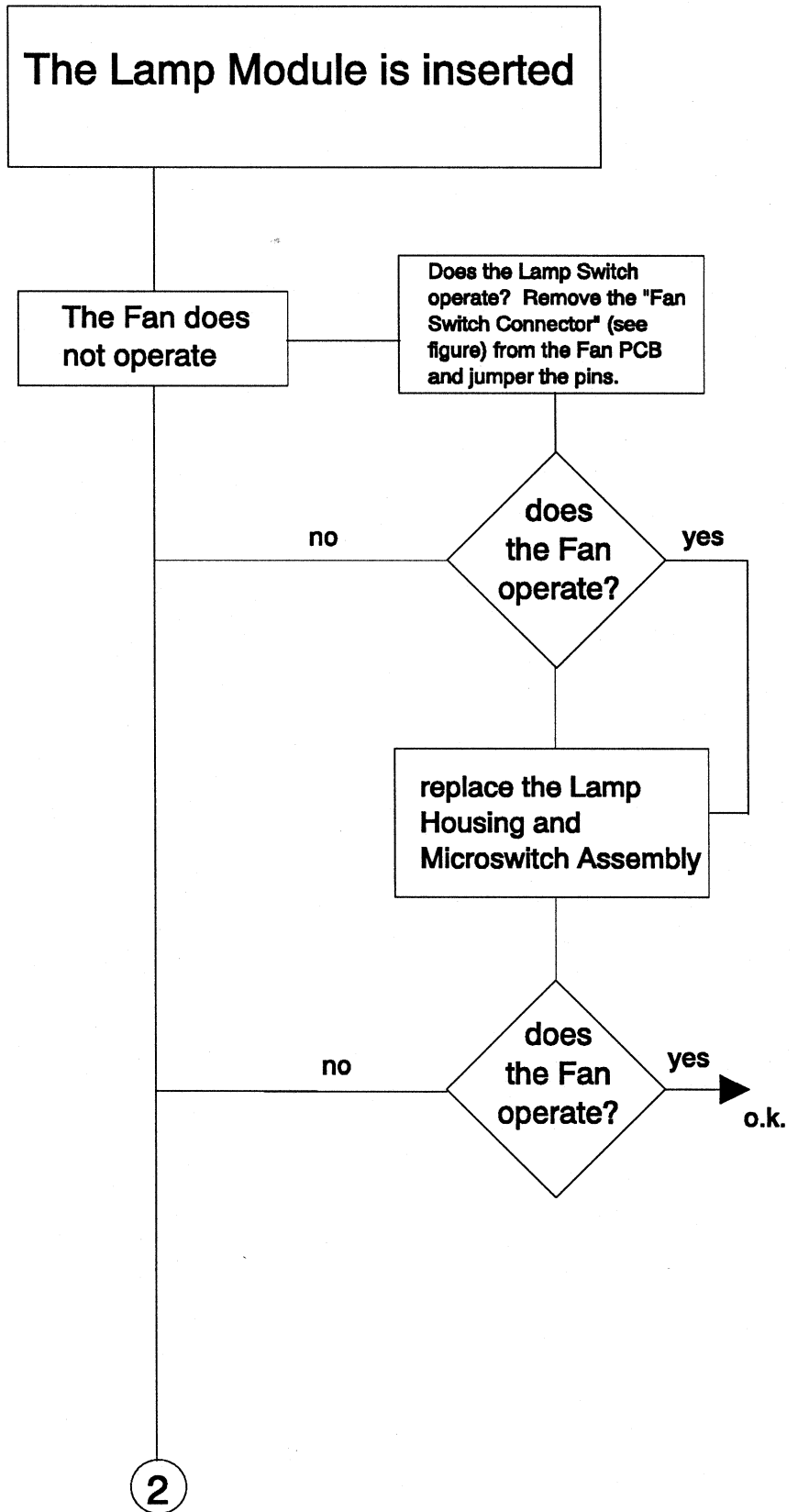

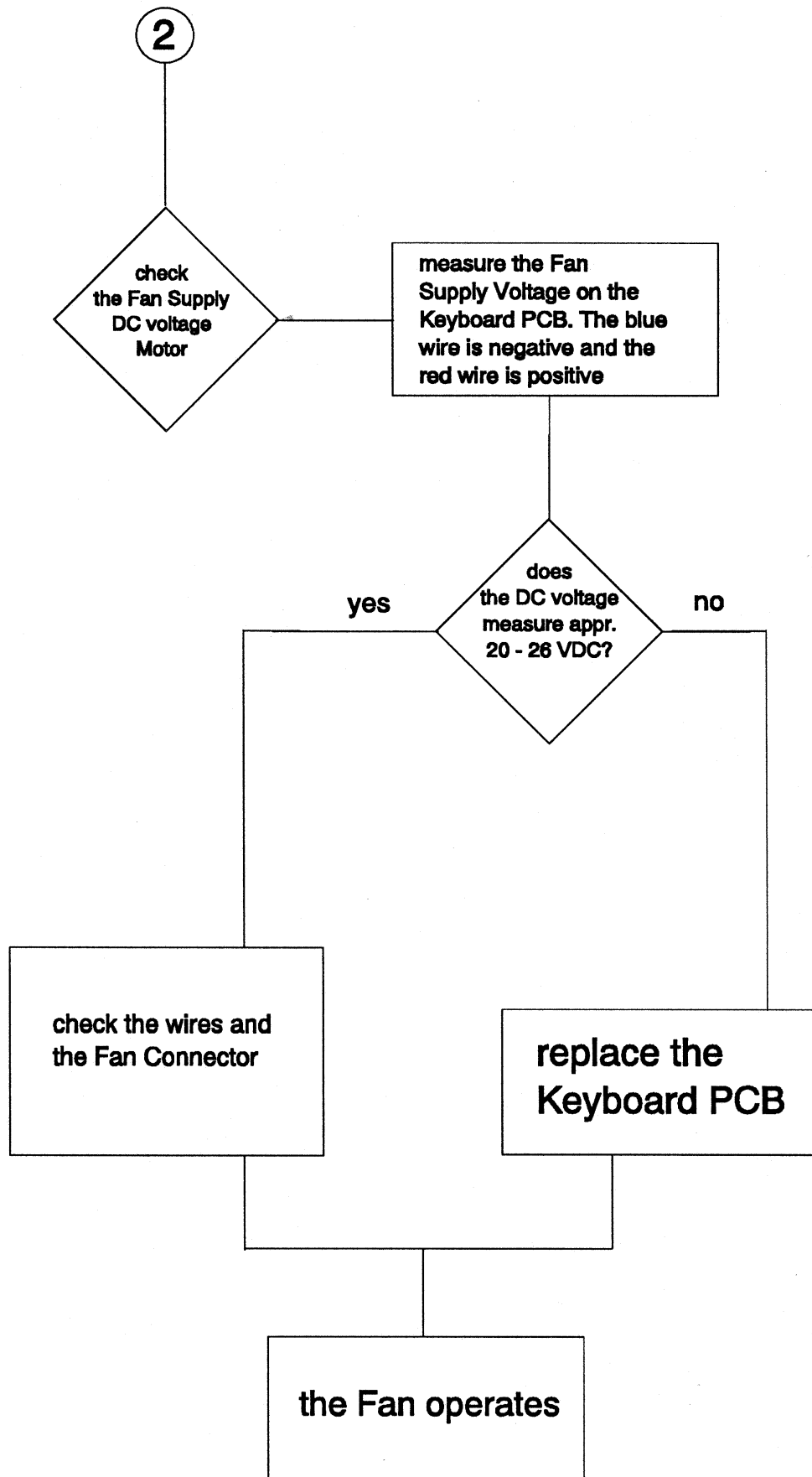

Slide Obstruction in Slide Tray

Conditions for a correct transport cycle

- Check SLIDE LIFTER LEVER. In the up position, the alignment above the CENTER HOUSING must be 3.8 mm (0.15 in.) with a tolerance of 0.2 mm (0.008 in.). If the measurement is greater, replace the SLIDE LIFT LEVER.
- Check the CENTER HOUSING for damaged parts such as:

DRIVE RING
GEAR WHEELS
CODER DISK

Inspect whether the parts are complete. Are there damaged or broken teeth on the wheels? If so, replace them.

Wrong Transport Step by 80/140 SLIDE TRAY

Condition:

Switch On Procedure o.k.

Projector does not change the step count *

*
Step count is only effective when the Drive Ring passed zero.

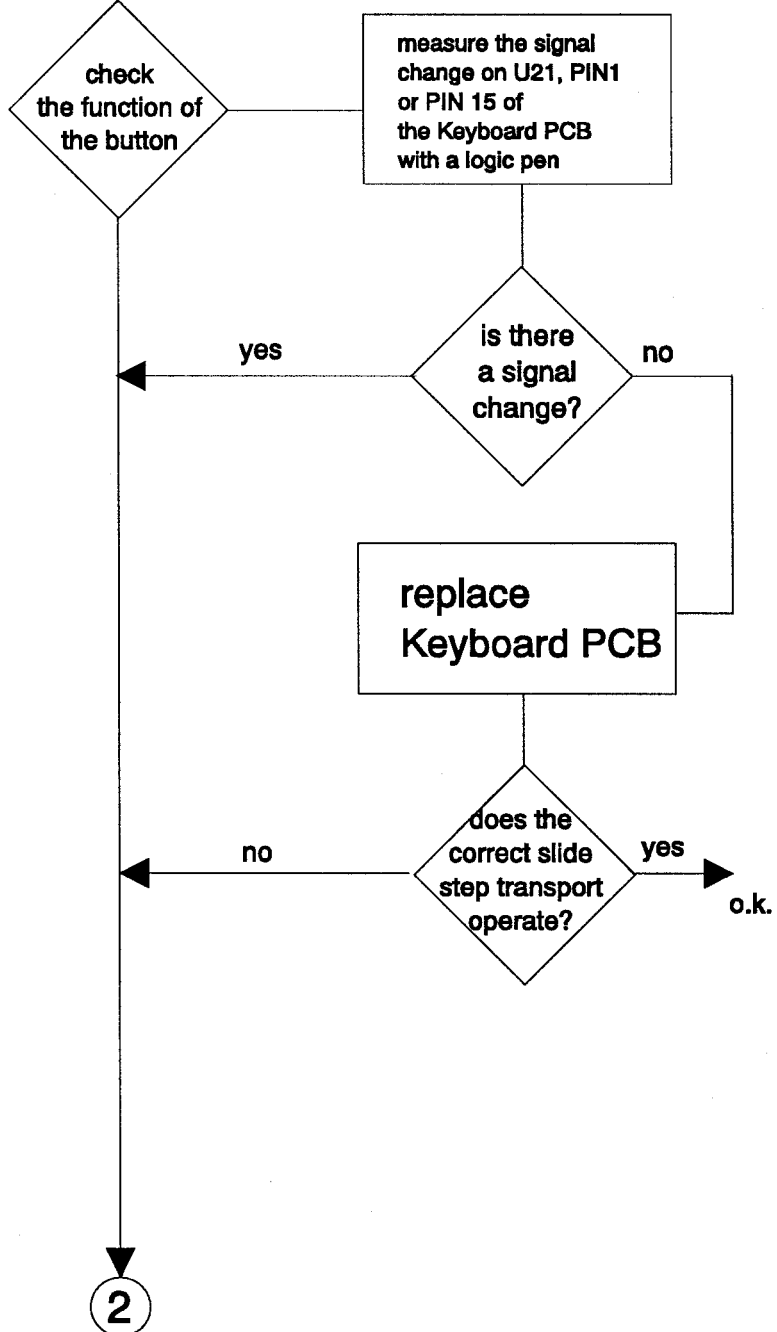

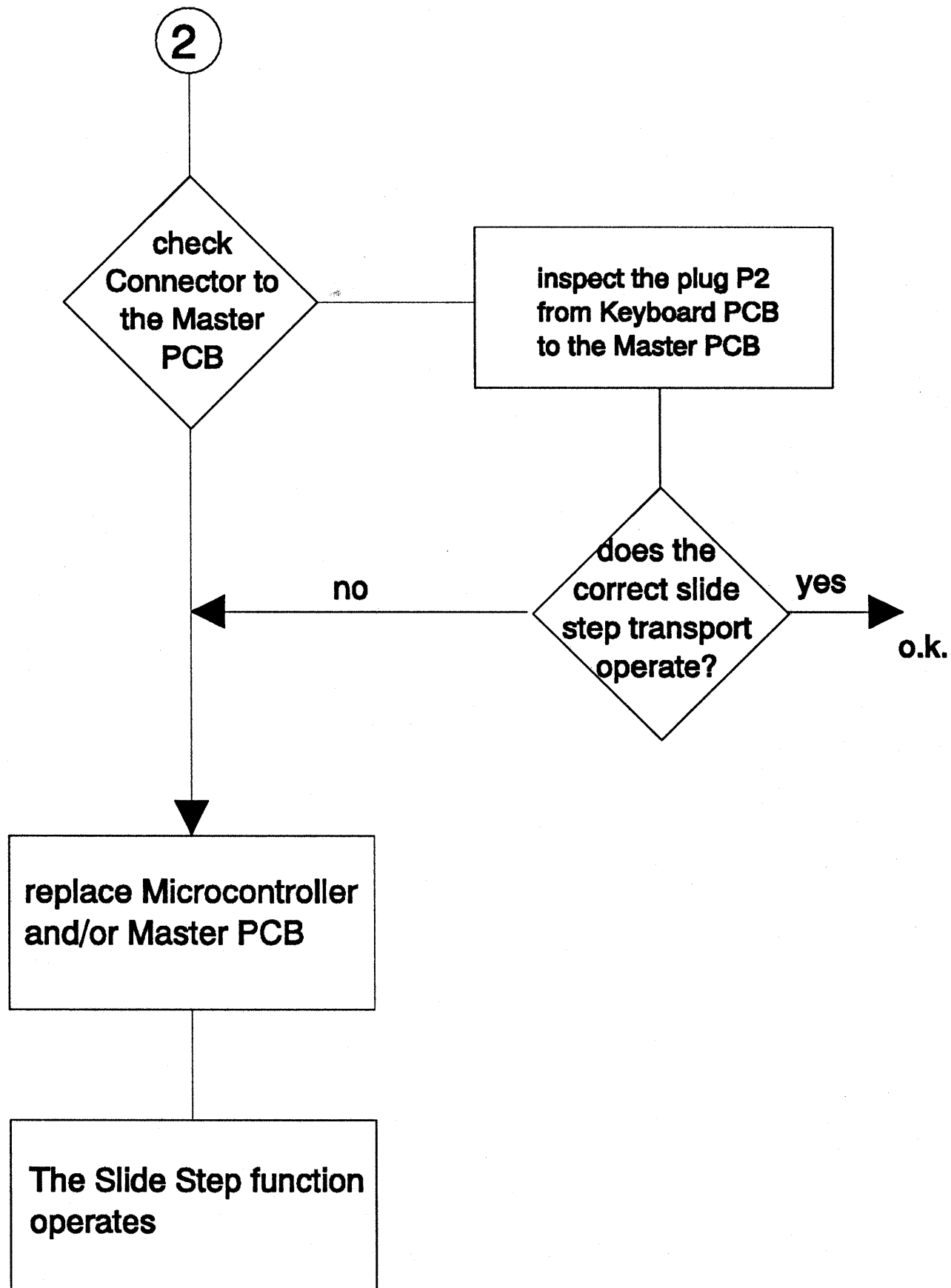

No Focus Actuation

Condition:

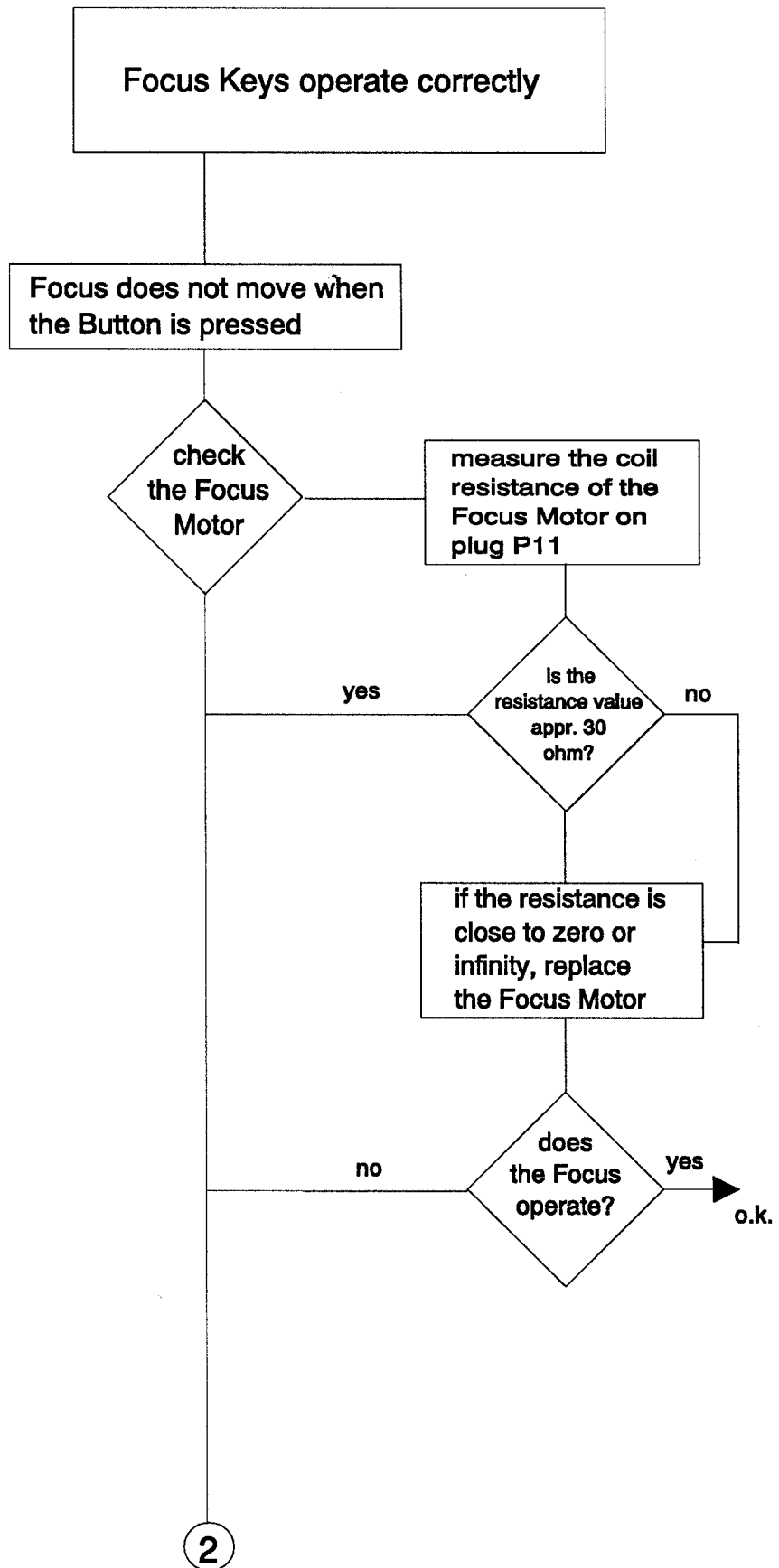

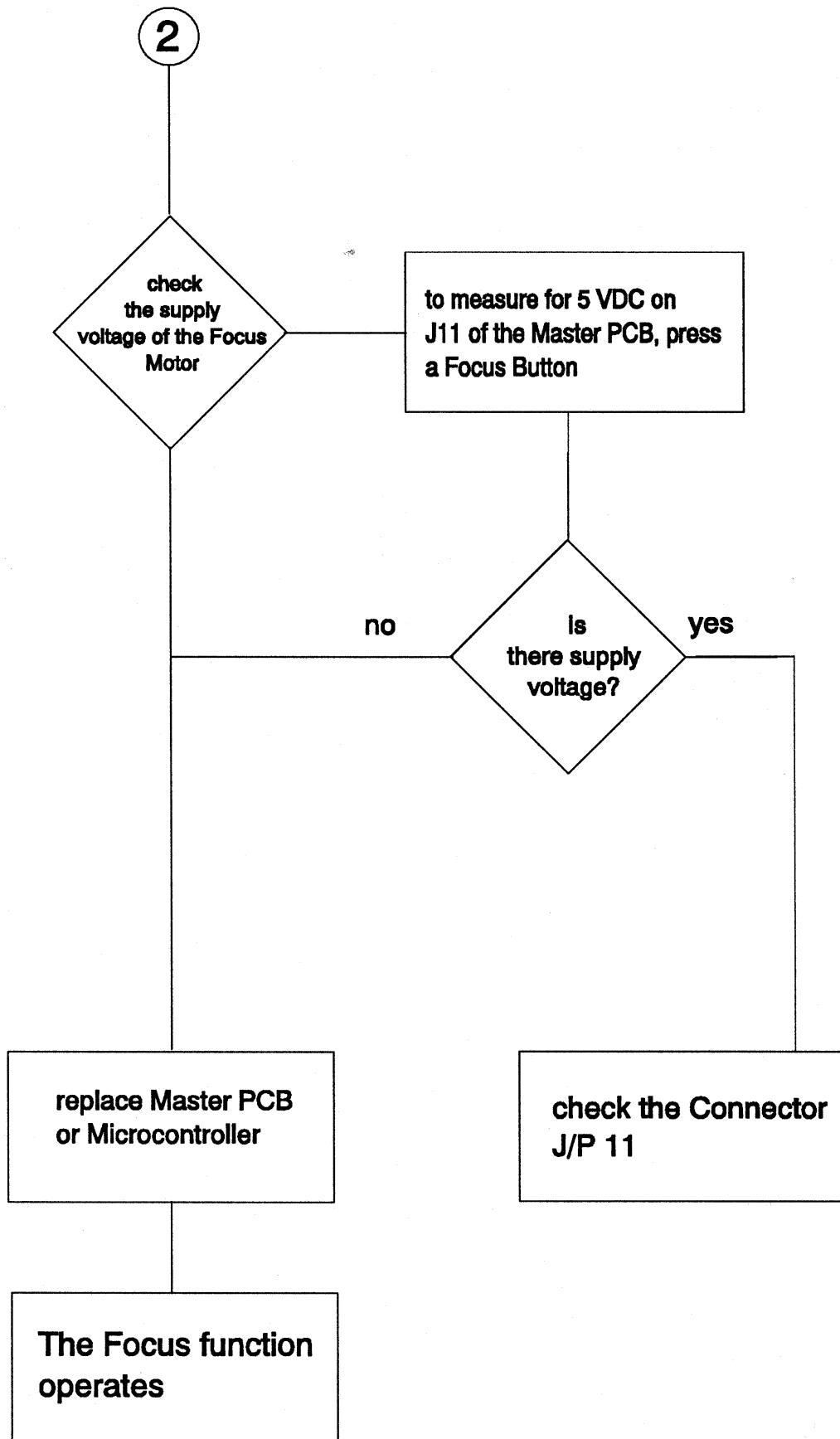

No Standby Function

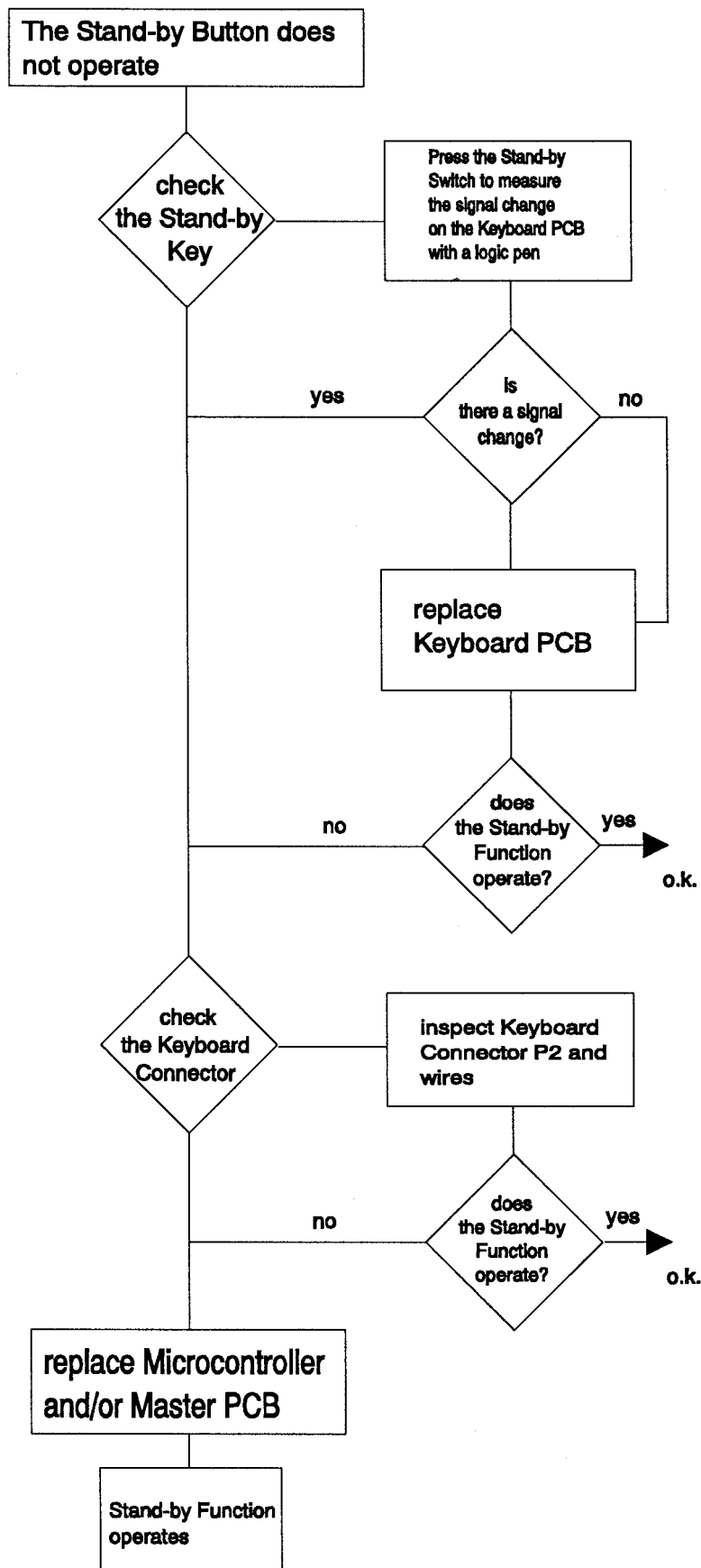

Communication Trouble 4020/5020/7020/9020 and 9020/CINE

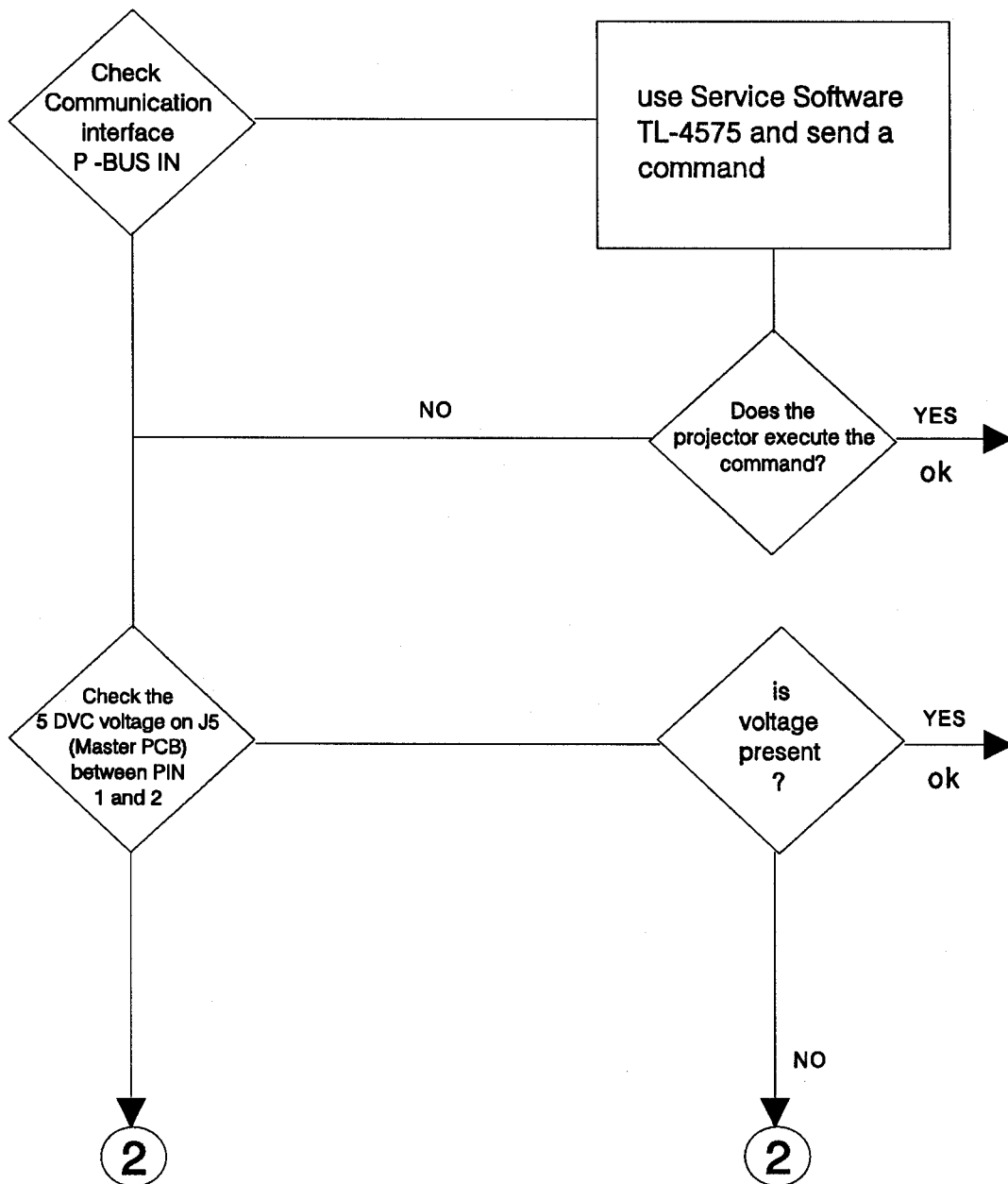
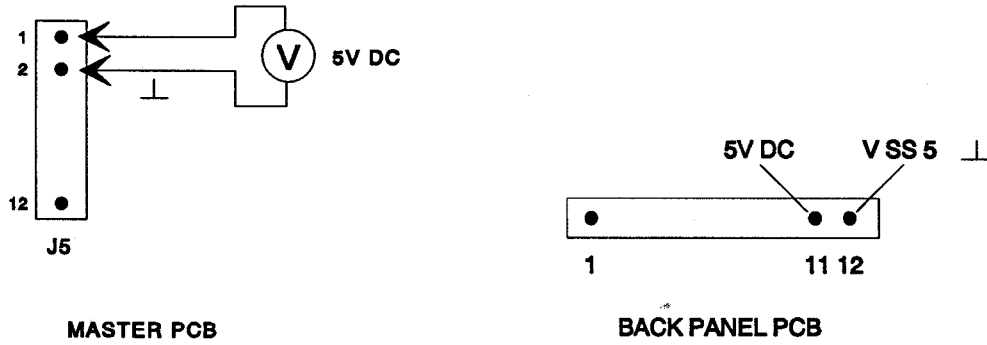

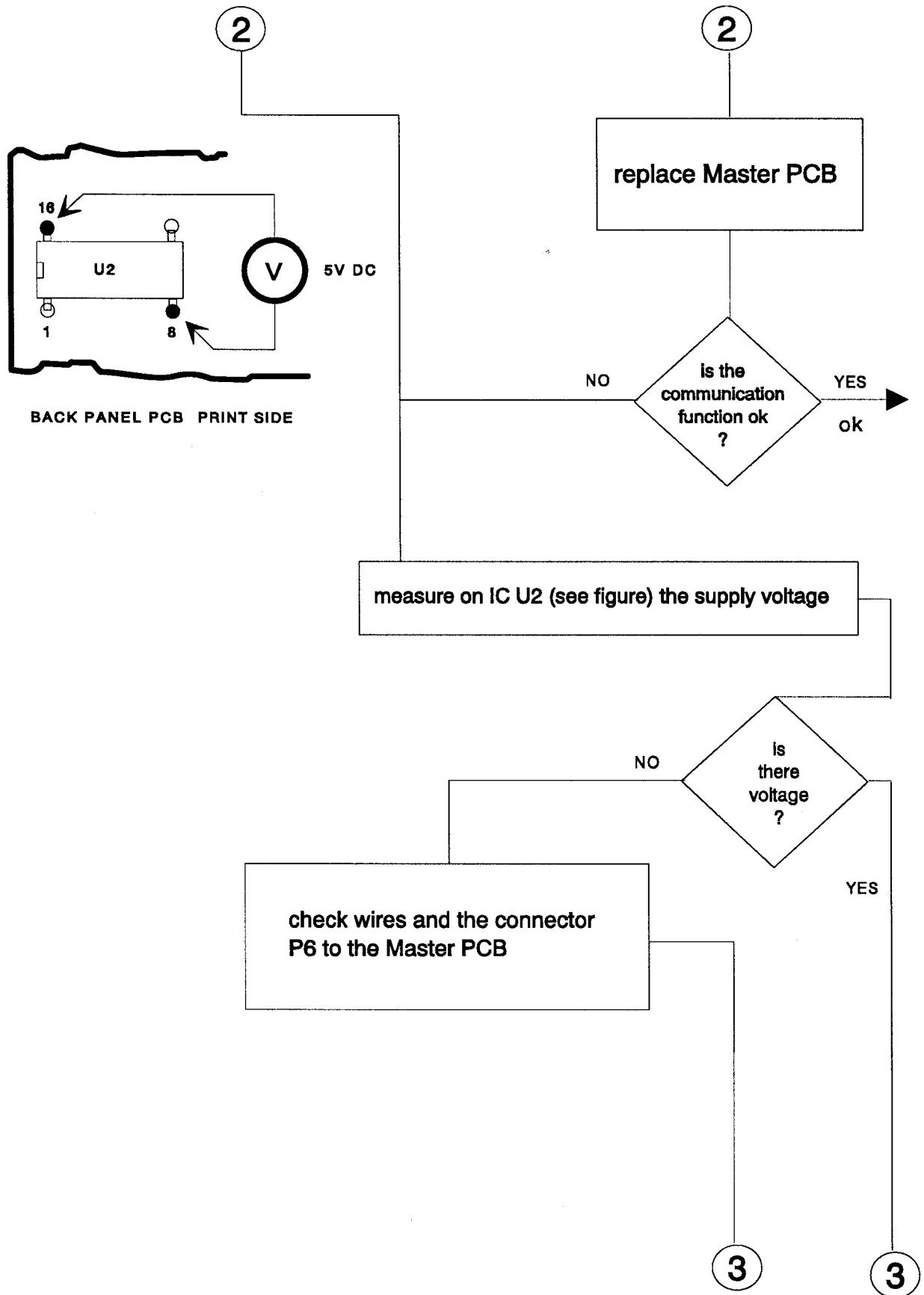

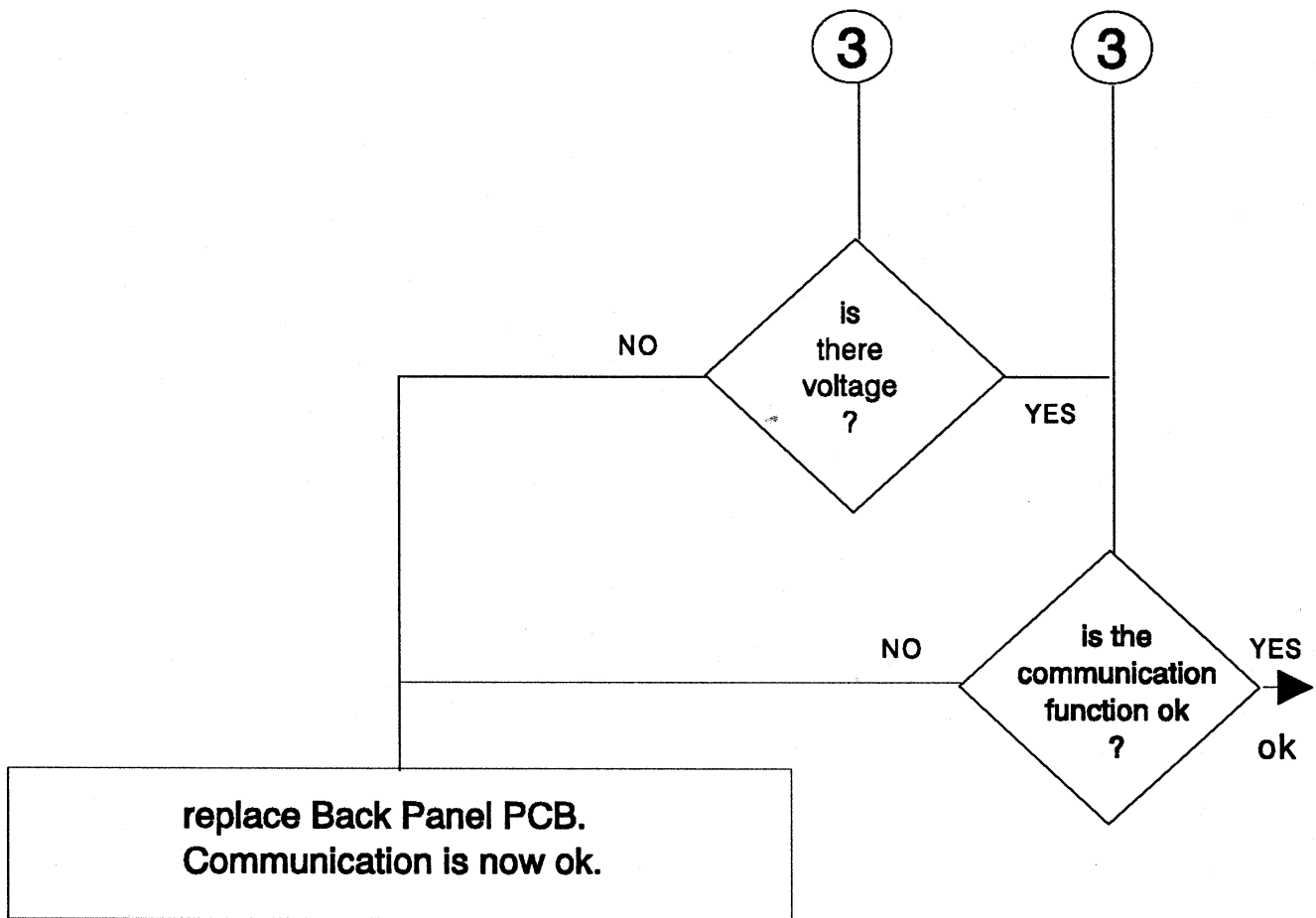

AUTO FOCUS 5020,9020 and 9020/CINE: No AUTO FOCUS Function

Condition:

Focus Motor operates by a command from the Keyboard or the Remote Control. Autofocus Switch "on"

Error condition: The Autofocus is defective

Remove Connector P3 from the Autofocus PCB, and measure the 5 VDC supply voltage

Measure on Master PCB on Test Point 5 VDC

is there 5 VDC on P3, PIN 1 ?

is 5 VDC on Test Point 5 VDC ?

replace Master PCB

2

IR-LED Pulses

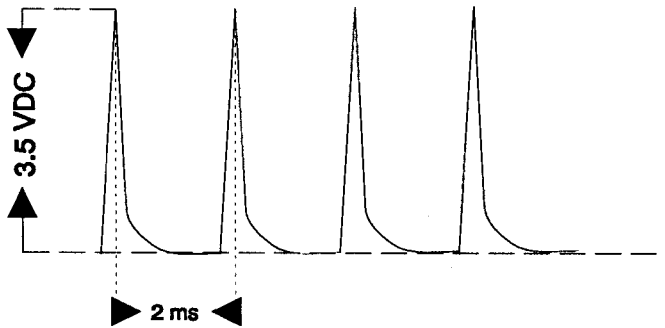

2

Check the function of the IR-LED. Measure the pulses on J/P2 PIN 1 with an oscilloscope. See figure.

replace IR-LED Assembly

are there pulses present ?

Receiver Pulses

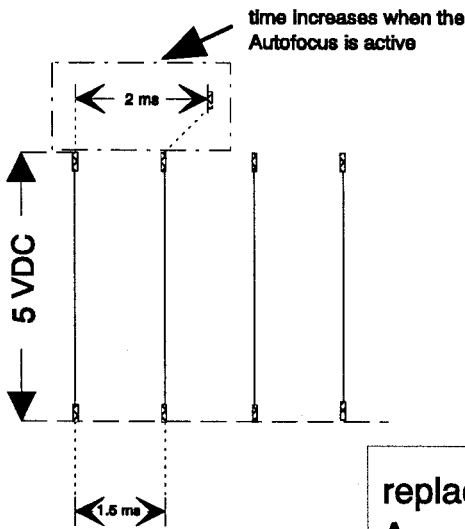

replace Receiver Assembly

Check the function of the Autofocus Receiver T1 or T2. Measure the pulses on PIN 2 or 3 with an oscilloscope. See figure.

are there pulses present ?

replace Autofocus PCB

*check Autofocus function

* For an easy check of the Autofocus function, push an inserted slide against the "pressure pad". A small movement of the slide is sufficient to start the Focus Motor.

Accessory Slot 7020/9020 and 9020/CINE

Malfunction of the 12/7 PIN Module

- Check the "TR5" fuses on the ADAPTER PCB F11 and F12. Each fuse is 0.8 A.
- If the change of the fuses was not successful or the fuses operate but the ADAPTER does not operate, use a new ADAPTER PCB.

6. Projector Checking

1. Power on the Projector. If there is no function and no initialization procedure, check the primary and the secondary Fuse F1 and F2.

Slide jam (all models)

2. To avoid slide jams check the position of the DRIVE RING. Use FIXTURE TOOL TL 622 0454 to adjust the TRAYMOTION PCB how it is described in Modification Instruction No.1

NOTE

Take care of the spring located at the rear side of the Metal Slide (see figure 6-1). The spring must be outside of the Slide Gate.

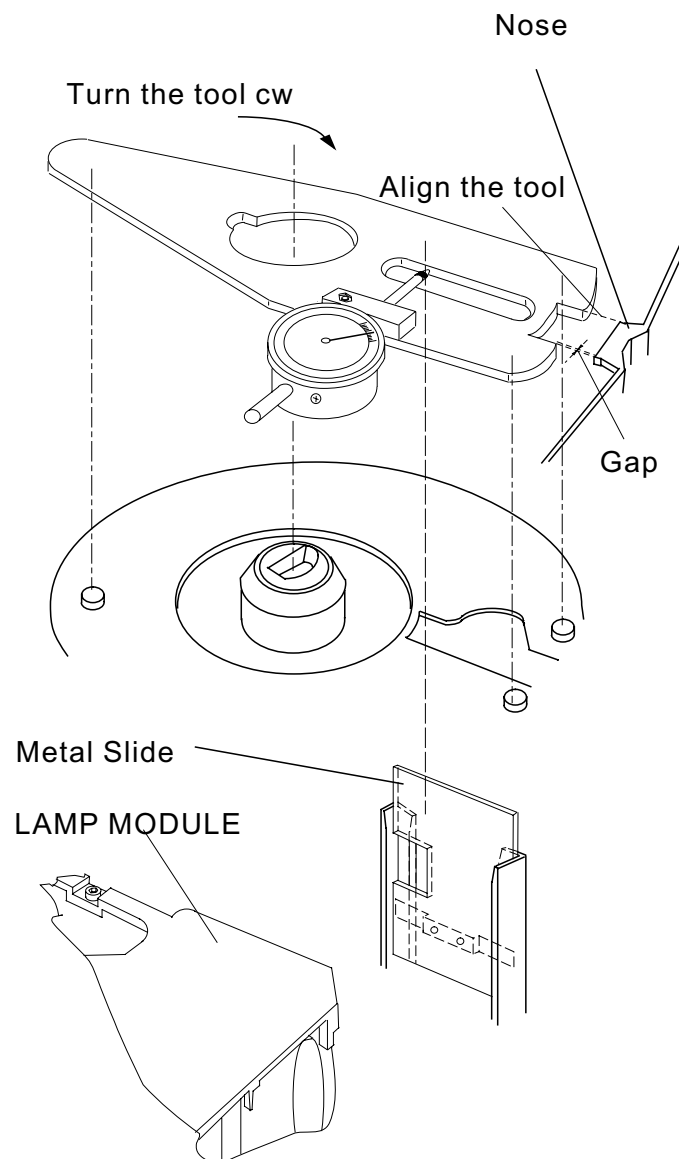

figure 6-1

CODER DISK

- Check bolts for proper fitting (see figure 6-2).
- Take care that the slots of the CODER DISK are free of dust.
- Ensure that the CODER DISK can free rotate and do not touch the LIGHT BARRIER.
- If there are still slide transport problems replace the TRAY MOTION PCB.

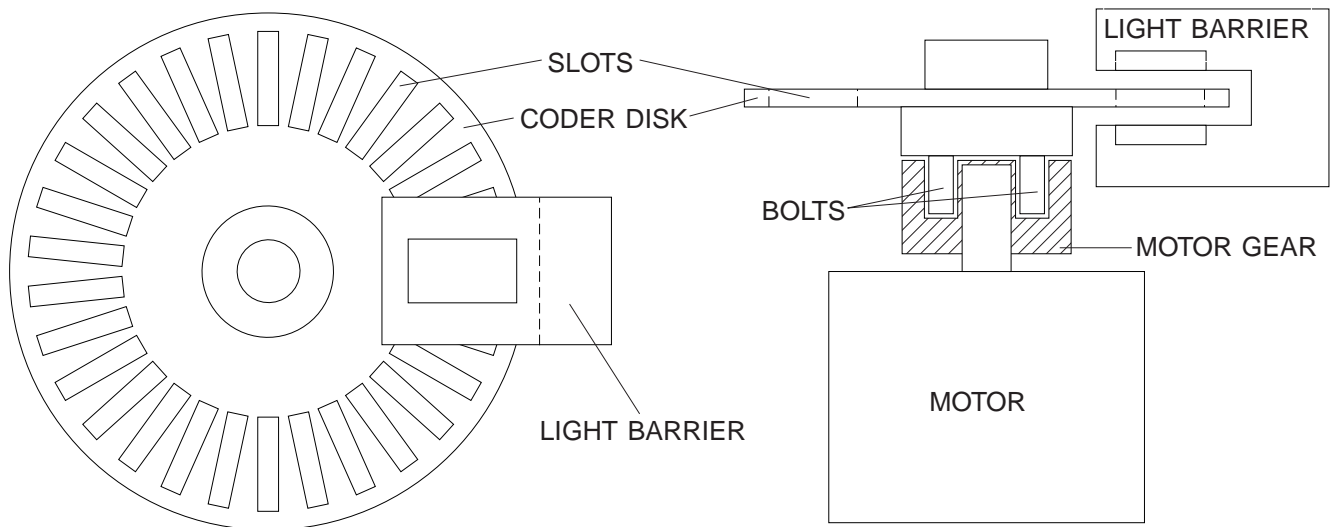

figure 6-2

7. MAINTENANCE

Maintenance Intervals

After about 1 500 running hours or 500 000 SLIDE LIFTER cycles at a room temperature of 0 - 40°C (32 - 104°F) we recommend maintenance by an authorized Kodak Service.

When the projector is operated in a dusty environment or in an enclosed area, maintenance should be done every 1000 operating hours or less, depending on the quantity of dust.

When operating in an enclosed area, supply the necessary air and exhaust. If needed, the enclosure should have an additional fan.

Maintenance Procedure

Open the projector. Clean with a dust cleaning device.

The following structural components should be dismantled, cleaned, if necessary parts replaced, lubricated and assembled.

Component	Page
Upper Housing	4-1
Center Housing	4-4/5/6/7
Fan, Keyboard PCB and Tray Motion PCB	4-8/9
Transformer, Power Supply PCB and Back Panel Assy	4-11
Mechanism Frame and Lens Mount	4-12
Lens Mount	4-13/14
Mechanism Frame	4-15/16/17

Cleaning of the other parts and structural components depends on how dirty they are.

See Item 4 DISASSEMBLY/ASSEMBLY.

Cleaning

It is important to clean the parts of the magazine drive and the diapositive transporter. See center housing, mechanism frame and lens mount. These parts should be cleaned thoroughly with a cleaner that does not damage the material.

The following parts should be checked for wear and, if necessary, replaced.

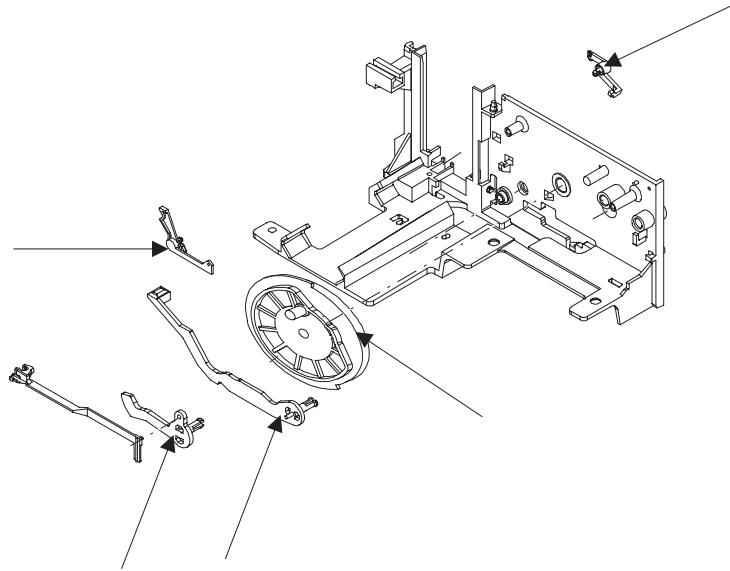

figure 7-1

The optical parts, such as LENS, CONDENSER LENS and HEAT ABSORBING GLASS should be cleaned regularly with lens cleaner.

Ultrasonic cleaning

At present, there is no information on the reactions of the individual components. We do not suggest this method.

Lubrication

Use the lubricant BARRIERTA L 25 DL (50 g) No. 558 1960.

NOTE

Never use any other oil or lubricants.

Grease all arrow marked spots.

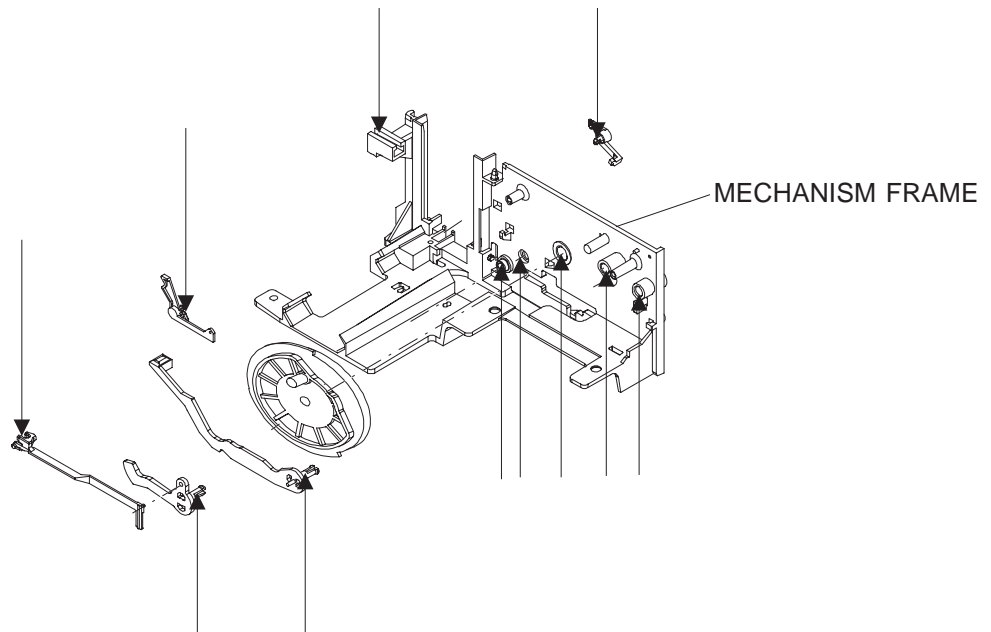

figure 7-2

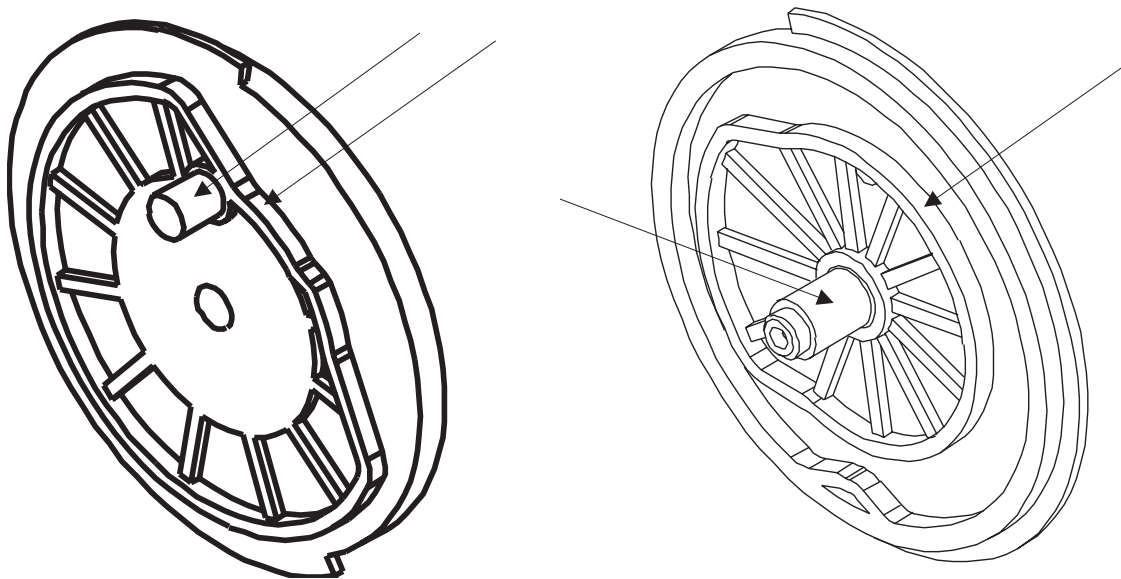

figure 7-3

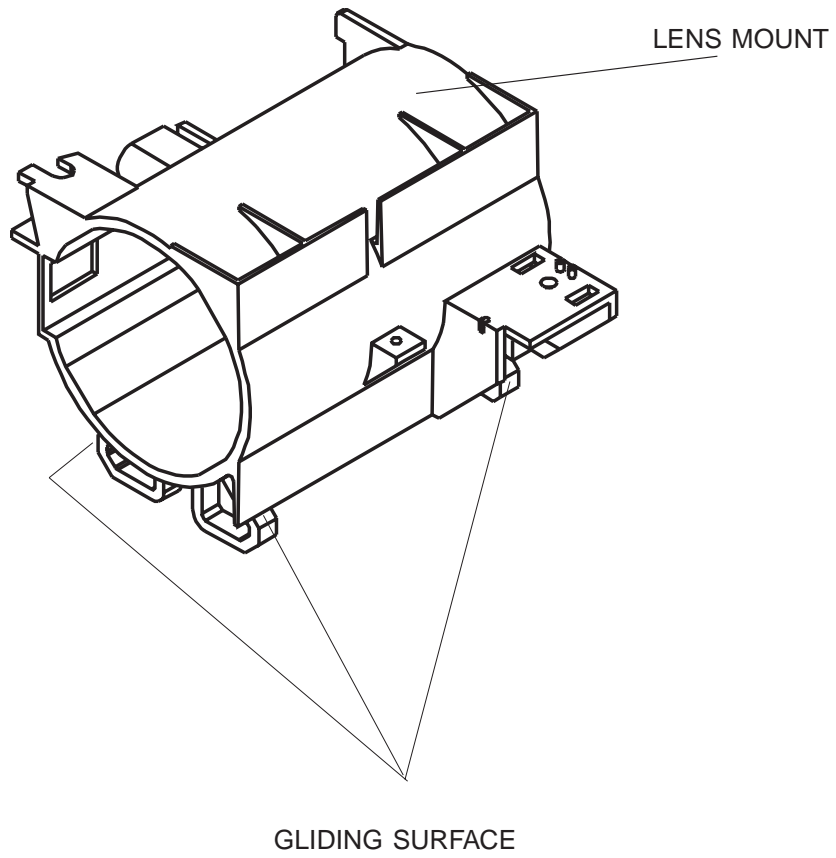

figure 7-4

blank page



CUSTOMER EQUIPMENT SERVICES KODAK AG STUTTGART GERMANY